

#### Features

- ON/OFF rotary handle with lockout provision
- Visible trip indication
- Test trip function
- Motor applications from 0.10A to 65A
- Class 10 overload protection
- Built-in heater and magnetic trip elements to protect the motor
- Phase loss sensitivity
- Type 2 coordination
- Ambient compensated up to 55°C [140°F]
- Control inputs located at front of starter for easy access and wiring
- Wide range of coils
- DIN rail mount—XTSC...BB\_
- Mounting plates—XTSC...BC\_, XTSC...D motor controllers
- Adjustment dial for setting motor FLA
- Short-circuit trip at 14 times the maximum setting of the FLA adjustment dial
- UL 508 Type F and Type E CMC high fault short-circuit ratings
- 1NO-1NC auxiliary contact as standard on manual motor controller and combination motor controller

#### Standards and Certifications

UL 508 Type F combination motor controller

- IEC Type 2 Approved per IEC 60947-4-1
- UL Listed File No. E245398
- CE Mark



**Note:** For Type 2 Coordination of MMCs, see **Page V5-T1-235**. Protection in different controller types

UL 508 Type E self-protected combination motor controller

- UL Listed File No. E123500



#### MMC and CMC Applications

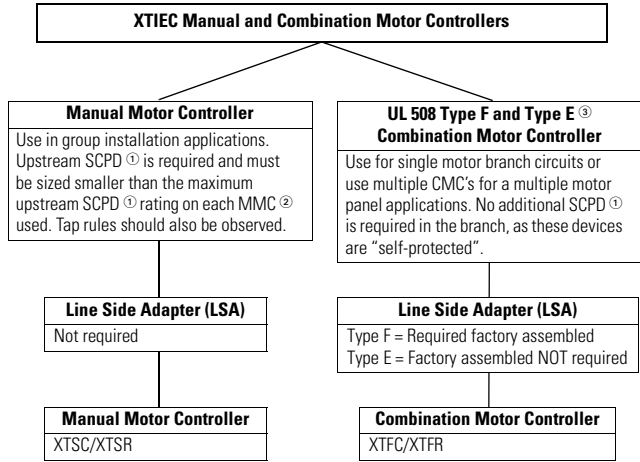

#### Notes

Technical Paper AP03402001E.

Line side adapters are not required for non-U.S. applications. Most countries outside of the U.S. classify the MMP as a motor-protective circuit breaker.

① SCPD = Short-circuit protective device (circuit breaker, fuses).

② MMC = Manual motor controller

③ Type E self-protected combination controller is the combination of a Type E self-protected device with a contactor.

Catalog Number Selection

Combination Motor Controllers

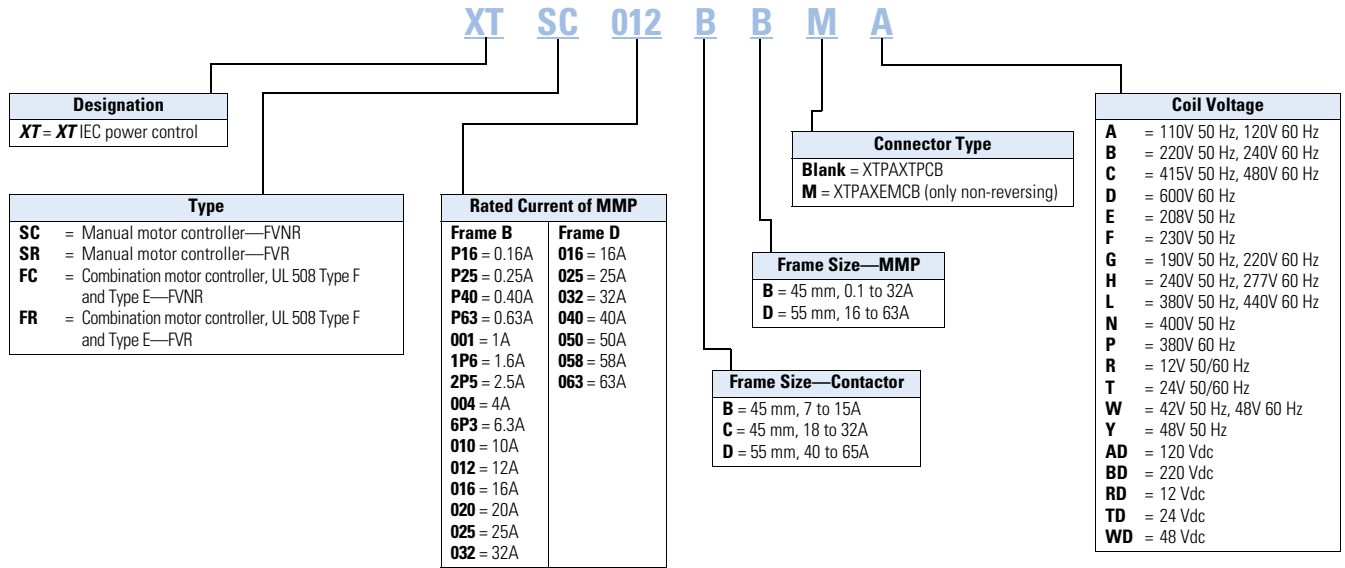

Product Selection

XTSC and XTSR Manual Motor Controllers (MMC)/Starter Combinations

Frame B MMP +  
Frame B Contactor

Factory-Assembled Manual Motor Controller—Frame B MMP + Frame B Contactor—  
Maximum UL Ratings ①



FLA Adjustment  
Range/Overload  
Release— $I_r$   
(Amps)



	Short-Circuit Release— $I_{rm}$ (Amps)	Three-Phase				Assembled Manual Motor Controller ②	
		200V	240V	480V	600V	Non-Reversing Catalog Number ③	Reversing Catalog Number
0.1–0.16	3.2	④	④	1/2	1/2	XTSCP16BB_	XTSRP16BB_
0.16–0.25	3.5	④	④	1/2	1/2	XTSCP25BB_	XTSRP25BB_
0.25–0.4	5.6	④	④	1/2	1/2	XTSCP40BB_	XTSRP40BB_
0.4–0.63	8.82	④	④	1/2	1/2	XTSCP63BB_	XTSRP63BB_
0.63–1	14	④	④	1/2	1/2	XTSC001BB_	XTSR001BB_
1–1.6	22.4	④	④	3/4	1	XTSC1P6BB_	XTSR1P6BB_
1.6–2.5	35	1/2	1/2	1	1-1/2	XTSC2P5BB_	XTSR2P5BB_
2.5–4	56	1	1	2	3	XTSC004BB_	XTSR004BB_
4–6.3	88.2	1-1/2	1-1/2	3	5	XTSC6P3BB_	XTSR6P3BB_
6.3–10	140	3	3	7-1/2	7.5	XTSC010BB_	XTSR010BB_
8–12	168	3	3	7-1/2	7.5	XTSC012BB_	XTSR012BB_
10–16	224	3	3	10	7.5	XTSC016BB_	—

Notes

- ① Select manual motor controllers by full load amperes. Maximum motor ratings (kW, hp) are for reference only.
- ② Underscore ( \_ ) indicates magnetic coil suffix required. See Page V5-T1-196.
- ③ "M" prior to ( \_ ) coil suffix will be assembled with standard connector XTPAXEMCB, non-reversing only.
- ④ In this range, calculate motor rating according to rated current. Specified values to NEC 430.6(A)(1).

## XTFC Non-Reversing Combination Motor Controllers—Component Bill of Material

## Factory Assembled Manual Motor Protector + Contactor + Line Side Adapter

Assembled Combination Motor Controller <sup>①</sup>	FLA Adjustment Range/ Overload Release— $I_r$ (Amps)	Component Catalog Numbers			Manual Motor Protector	Combination Connection Kit	Contactor <sup>①</sup>	Manual Motor Protector Auxiliary Contact
		Line Side Adapter	Manual Motor Protector	Combination Connection Kit				
<b>XTFC Frame B MMP + Frame B Contactor</b>								
XTFCP16BB_ <sup>②</sup>	0.1–0.16	XTPAXLSA	XTPRP16BC1	XTPAXTPCB	XTCE007B10_	XTPAXFA11		
XTFCP25BB_ <sup>②</sup>	0.16–0.25	XTPAXLSA	XTPRP25BC1	XTPAXTPCB	XTCE007B10_	XTPAXFA11		
XTFCP40BB_ <sup>②</sup>	0.25–0.4	XTPAXLSA	XTPRP40BC1	XTPAXTPCB	XTCE007B10_	XTPAXFA11		
XTFCP63BB_ <sup>②</sup>	0.4–0.63	XTPAXLSA	XTPRP63BC1	XTPAXTPCB	XTCE007B10_	XTPAXFA11		
XTFC001BB_ <sup>②</sup>	0.63–1	XTPAXLS	XTPR001BC1	XTPAXTPCB	XTCE007B10_	XTPAXFA11		
XTFC1P6BB_ <sup>②</sup>	1–1.6	XTPAXLSA	XTPR1P6BC1	XTPAXTPCB	XTCE007B10_	XTPAXFA11		
XTFC2P5BB_ <sup>②</sup>	1.6–2.5	XTPAXLSA	XTPR2P5BC1	XTPAXTPCB	XTCE007B10_	XTPAXFA11		
XTFC004BB_ <sup>②</sup>	2.5–4	XTPAXLSA	XTPR004BC1	XTPAXTPCB	XTCE007B10_	XTPAXFA11		
XTFC6P3BB_ <sup>②</sup>	4–6.3	XTPAXLSA	XTPR6P3BC1	XTPAXTPCB	XTCE007B10_	XTPAXFA11		
XTFC010BB_ <sup>②</sup>	6.3–10	XTPAXLSA	XTPR010BC1	XTPAXTPCB	XTCE009B10_	XTPAXFA11		
XTFC012BB_ <sup>②</sup>	8–12	XTPAXLSA	XTPR012BC1	XTPAXTPCB	XTCE012B10_	XTPAXFA11		
XTFC016BB_ <sup>②</sup>	10–16	XTPAXLSA	XTPR016BC1	XTPAXTPCB	XTCE015B10_	XTPAXFA11		
<b>XTFC Frame B MMP + Frame C Contactor</b>								
XTFC6P3BC_ <sup>②</sup>	4–6.3	XTPAXLSA	XTPR6P3BC1	XTPAXTPCC	XTCE018C10_	XTPAXFA11		
XTFC010BC_ <sup>②</sup>	6.3–10	XTPAXLSA	XTPR010BC1	XTPAXTPCC	XTCE018C10_	XTPAXFA11		
XTFC012BC_ <sup>②</sup>	8–12	XTPAXLSA	XTPR012BC1	XTPAXTPCC	XTCE018C10_	XTPAXFA11		
XTFC016BC_ <sup>②</sup>	10–16	XTPAXLSA	XTPR016BC1	XTPAXTPCC	XTCE018C10_	XTPAXFA11		
XTFC020BC_ <sup>②</sup>	16–20	XTPAXLSA	XTPR020BC1	XTPAXTPCC	XTCE025C10_	XTPAXFA11		
XTFC025BC_ <sup>②</sup>	20–25	XTPAXLSA	XTPR025BC1	XTPAXTPCC	XTCE025C10_	XTPAXFA11		
XTFC032BC_ <sup>②</sup>	25–32	XTPAXLSA	XTPR032BC1	XTPAXTPCC	XTCE032C10_	XTPAXFA11		
<b>XTFC Frame D MMP + Frame C Contactor</b>								
XTFC016DC_ <sup>②</sup>	10–16	XTPAXLSAD	XTPR016DC1	③	XTCE018C10_	XTPAXFA11		
XTFC025DC_ <sup>②</sup>	16–25	XTPAXLSAD	XTPR025DC1	③	XTCE025C10_	XTPAXFA11		
XTFC032DC_ <sup>②</sup>	25–32	XTPAXLSAD	XTPR032DC1	③	XTCE032C10_	XTPAXFA11		
<b>XTFC Frame D MMP + Frame D Contactor</b>								
XTFC016DD_ <sup>②</sup>	10–16	XTPAXLSAD	XTPR016DC1	XTPAXTPCD	XTCE040D00_	XTPAXFA11		
XTFC025DD_ <sup>②</sup>	16–20	XTPAXLSAD	XTPR025DC1	XTPAXTPCD	XTCE040D00_	XTPAXFA11		
XTFC032DD_ <sup>②</sup>	20–25	XTPAXLSAD	XTPR032DC1	XTPAXTPCD	XTCE040D00_	XTPAXFA11		
XTFC040DD_ <sup>②</sup>	32–40	XTPAXLSAD	XTPR040DC1	XTPAXTPCD <sup>④</sup>	XTCE040D00_	XTPAXFA11		
XTFC050DD_ <sup>②</sup>	40–50	XTPAXLSAD	XTPR050DC1	XTPAXTPCD <sup>④</sup>	XTCE050D00_	XTPAXFA11		
XTFC058DD_ <sup>②</sup>	50–58	XTPAXLSAD	XTPR058DC1	XTPAXTPCD <sup>④</sup>	XTCE065D00_	XTPAXFA11		
XTFC063DD_ <sup>②</sup>	55–65	XTPAXLSAD	XTPR063DC1	XTPAXTPCD <sup>④</sup>	XTCE065D00_	XTPAXFA11		

## Notes

① Underscore ( \_ ) indicates magnetic coil suffix required. See **Page V5-T1-196**.

② Indicates Type E with contactor UL 508 combination. Not all XTFC part numbers feature UL 508 Type E with contactor combinations.

③ The connection between the XTPR...DC1 and the XTCE...C\_ contactor will be made with flexible wire and mounted to the DIN rail adapter plate (XTPAXTPCPD).

④ The reversing connection between the XTPR...DC1 and the (2) XTCE...C\_ contactors will be accomplished by using the non-reversing combination connection kit (XTPAXTPCD), Frame D reversing link kit (XTCEXRLD), additional DIN rail adapter plate (XTPAXTPCPD) and DIN adapter connection element (XTPAXCNE).

**Note:** Type E UL 508 combinations can be assembled in the field and DO NOT require the manual motor protector auxiliary contact XTPAXFA11. The connection can also be wired and does not require use of the XT connector.

**XT Electronic Manual Motor Protector****XT Electronic Manual Motor Protector****Product Description**

The **XT** Electronic Manual Motor Protector provides the same functionality as the **XT** thermal manual motor protector, but with an added level of flexibility and selectability. The XTPE incorporates electronic control technology to enable more options and larger dial setting ranges. The trip units are interchangeable, allowing users to exchange as needed using the same base. The reduced number of part numbers decreases bill of material complexity while reducing inventory demands. The XTPE electronic manual motor protector includes the following features:

- 4:1 max to min overcurrent dial setting range
- Selectable trip class (5, 10, 15, 20)
- Interchangeable trip units
- Three base units (12, 32 and 65A)
- Common accessories with the XTPR

**Features and Benefits****Advanced Trip Unit**

In addition to the selectability, the XTPE is also available with an advanced trip unit that can communicate system data and protector data thru SmartWire-DT. SmartWire-DT is an innovative cost effective connection technology that enables quick installation of control wiring to the starter through a single green cable. When on SmartWire-DT, the XTPE can communicate the following:

- Current Values
  - Maximum phase current
  - Overload warning

**Contents****Description**

	<b>Page</b>
Relays and Timers .....	<b>V5-T1-3</b>
Miniature Controls .....	<b>V5-T1-18</b>
Contactors and Starters .....	<b>V5-T1-35</b>
Thermal Overload Relays .....	<b>V5-T1-128</b>
C440/ <b>XT</b> Electronic Overload Relay .....	<b>V5-T1-141</b>
Manual Motor Protectors .....	<b>V5-T1-157</b>
Combination Motor Controllers .....	<b>V5-T1-191</b>
<b>XT</b> Electronic Manual Motor Protector	
Catalog Number Selection .....	<b>V5-T1-218</b>
Product Selection .....	<b>V5-T1-219</b>
Accessories .....	<b>V5-T1-221</b>
Technical Data and Specifications .....	<b>V5-T1-227</b>
Dimensions .....	<b>V5-T1-229</b>
EMS—Electronic Motor Starter .....	<b>V5-T1-230</b>
<b>XT</b> DC Contactors .....	<b>V5-T1-232</b>
Reference Data .....	<b>V5-T1-234</b>

**Standards and Certifications**

- CE approved
- UL Listed File No. E36332
- UL 508 group motor and Type E
- IEC/EN 60947
- CSA File 012528, Class 3211-05



- Diagnostics Data
  - Overload fault
  - Cause of trip (overcurrent or short circuit)
  - Phase loss
  - Trip via TEST
- Status Messages
  - Control unit type
  - Overload setting
  - Time-lag
  - Switching status

**XTPE Electronic MMP**

The XTPE Electronic MMP provides the selectability, control, and insight options that give panel builders and OEMs the solutions necessary to enhance motor control designs while reducing total costs.

#### 1

### Catalog Number Selection

#### XT—Manual Motor Protector

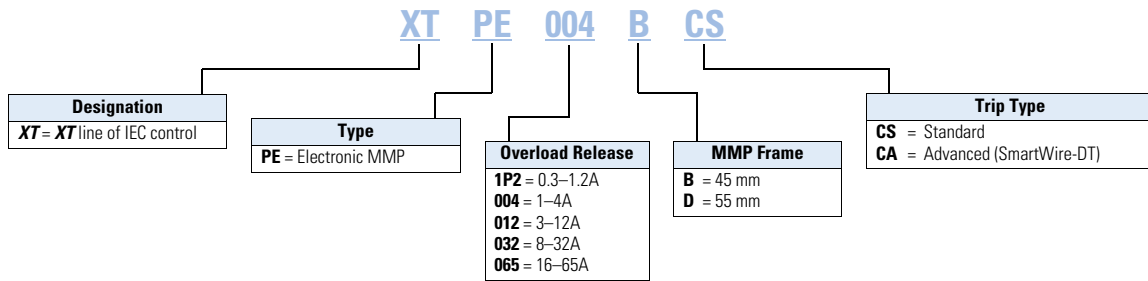

#### XT—Combinations

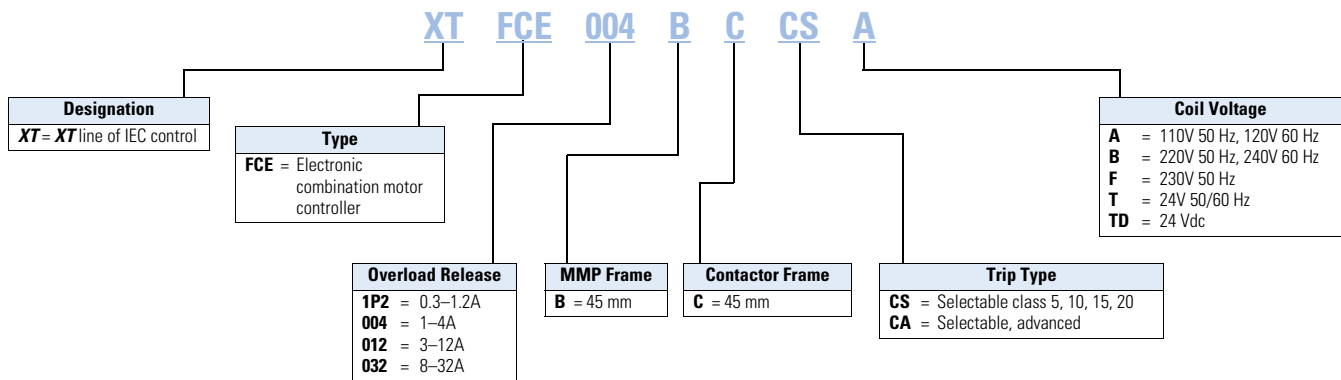

1

B Frame

#### MMP Used with SmartWire-DT—Complete Assembly



Overload Release Setting Amp Range	UL/CSA Maximum Motor hp Ratings				IEC Maximum Motor kW Ratings						Complete Manual Motor Protector	
	200V	230V	460V	575V	220V 230V 240V	380V 400V 415V	440V	500V	600V 690V	Type Number	Catalog Number	
	0.3–1.2	①	①	0.5	0.5	0.18	0.37	0.37	0.37	0.75	PKE12/XTUA-1,2	<b>XTPE1P2BCA</b>
1–4	0.75	0.75	2	3	0.75	1.5	1.5	2.2	3	PKE12/XTUA-4	<b>XTPE004BCA</b>	
3–12	3	3	7.5	10	3	5.5	5.5	5.5	7.5	PKE12/XTUA-12	<b>XTPE012BCA</b>	
8–32	5	7.5	15	20	7.5	15	15	18.5	30	PKE32/XTUA-32	<b>XTPE032BCA</b>	

#### UL 508 Type E XT Electronic Combination Motor Controllers—Complete Assembly Including Trip Unit

B Frame

#### B Frame Electronic MMP with C Frame Contactor



Overload Release Setting Amp Range	UL/CSA Maximum Three-Phase hp Ratings					Maximum Single-Phase hp Ratings			Catalog Number Standard	Catalog Number With SmartWire-DT
	200V	240V	380V/ 415V	480V/ 277V	600V/ 347V	115V	200V	240V		
0.3–1.2	①	①	①	①	0.5	①	①	①	<b>XTFCE1P2BCCS_</b> ③	<b>XTFCE1P2BCCATD</b> ③
1–4	0.75	0.75	1.5	2	—	0.125	0.25	0.33	<b>XTFCE004BCCS_</b> ④	<b>XTFCE004BCCATD</b> ④
3–12	3	3	5	7.5	—	0.5	1	1.5	<b>XTFCE012BCCS_</b> ④	<b>XTFCE012BCCATD</b> ④
8–32	5	5	10	15	—	1.5	3	3	<b>XTFCE032BCCS_</b> ④	<b>XTFCE032BCCATD</b> ④

#### Notes

- ① In this range, calculate motor rating according to rated current. Specified values to NEC 430.6 (A) (1).
- ② Complete the catalog number by replacing the underscore (\_) with the coil suffix from **Page V5-T1-243**.
- ③ SCCR: 14 kA, 600 Vac
- ④ SCCR: 18 kA, 480 Vac