

# CrossRail Tilt Up System

## TECHNICAL SHEET

Item Number	Description	Part Number
1	CrossRail 44-X (shown) all CR profiles applicable	4000019 [166" mill], 4000020 [166" dark] , 4000021 [180" mill], 4000022 [180" dark]
2	CrossRail Mid Clamp	4000601-H [mill], 4000602-H [dark]
3	CrossRail [Standard] End Clamp	4000429 [mill], 4000430 [dark]
4	Yeti Hidden End Clamp for CR	4000050-H
5	Climber Set w/ Hole, 13mm Hex	40006042-H [48-X, 48-XL] 4006043 [44-X]
6	CrossRail Tilt Connector Set	4000505
7	L-Foot Slotted Set	4000630 [mill], 4000631 [dark]
8	CrossRail 44-X Rail Connector (shown) CR 48-X, 48-XL Rail Connector available	4000051 [mill], 4000052 [dark]
9	Everest Ground Lug	4000006-H
10	CrossRail 44-X End Cap (shown) CrossRail 48-X, 48-XL and 80 available	4000067

Units: [mm] in

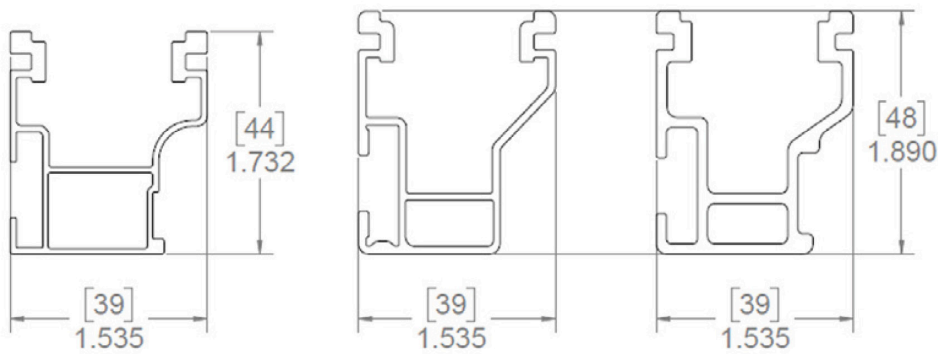

## Technical Data

CrossRail Tilt Up System	
Roof Type	Composition shingle, tile, standing seam
Material	High corrosion resistance stainless steel and high grade aluminum
Flexibility	Modular construction, suitable for any system size, height adjustable
PV Modules	For all common module types
Module Orientation	Portrait and landscape
Roof Connection	Drill connection into rafter
Structural Validity	IBC compliant, stamped engineering letters available for all solar states
Warranty	25 years

# CROSSRAIL 44-X

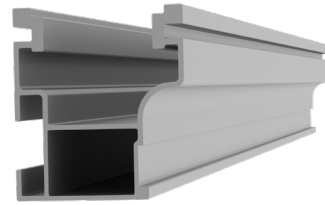

## Mechanical Properties

	CrossRail 44-X
Material	6000 Series Aluminum
Ultimate Tensile Strength	37.7 ksi [260 MPa]
Yield Strength	34.8 ksi [240 MPa]
Weight	0.47 lbs/ft [0.699 kg/m]
Finish	Mill or Dark Anodized

## Sectional Properties

	CrossRail 44-X
Sx	0.1490 in <sup>3</sup> [0.3785 cm <sup>3</sup> ]
Sy	0.1450 in <sup>3</sup> [0.3683 cm <sup>3</sup> ]
A [X-Section]	0.4050 in <sup>2</sup> [1.0287 cm <sup>2</sup> ]

Units: [mm] in

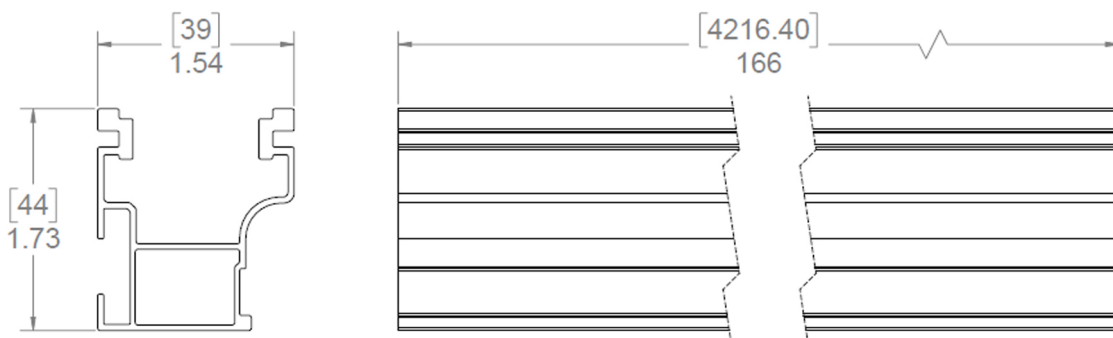

### Notes:

- ▶ Structural values and span charts determined in accordance with Aluminum Design Manual and ASCE 7-16
- ▶ UL2703 Listed System for Fire and Bonding

# CROSSRAIL 48-X

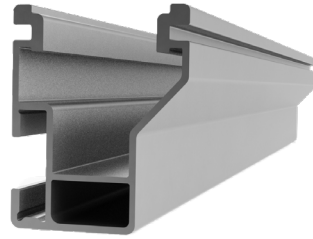

## Mechanical Properties

	CrossRail 48-X
Material	6000 Series Aluminum
Ultimate Tensile Strength	37.7 ksi [260 MPa]
Yield Strength	34.8 ksi [240 MPa]
Weight	0.56 lbs/ft [0.833 kg/m]
Finish	Mill or Dark Anodized

## Sectional Properties

	CrossRail 48-X
Sx	0.1980 in <sup>3</sup> [3.245 cm <sup>3</sup> ]
Sy	0.1510 in <sup>3</sup> [2.474 cm <sup>3</sup> ]
A [X-Section]	0.4650 in <sup>2</sup> [2.999 cm <sup>2</sup> ]

Units: [mm] in

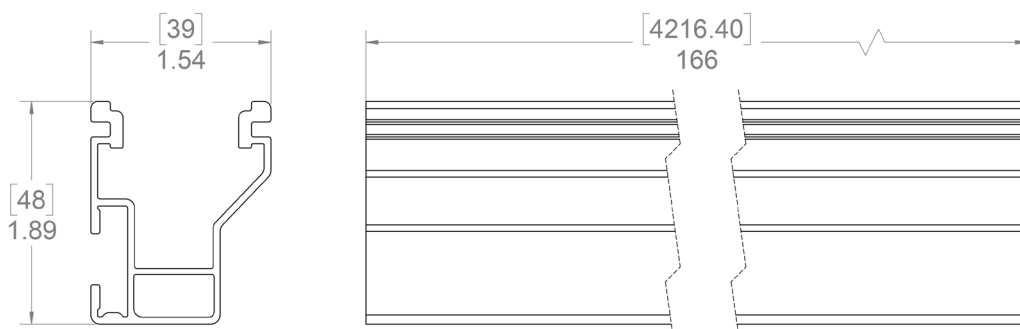

### Notes:

- ▶ Structural values and span charts determined in accordance with Aluminum Design Manual and ASCE 7-16
- ▶ UL2703 Listed System for Fire and Bonding

# CROSSRAIL 48-XL

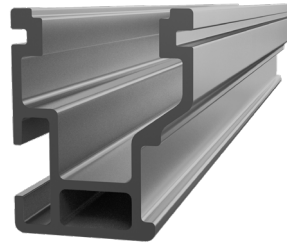

## Mechanical Properties

	CrossRail 48-XL
Material	6000 Series Aluminum
Ultimate Tensile Strength	37.7 ksi [260 MPa]
Yield Strength	34.8 ksi [240 MPa]
Weight	0.76 lbs/ft [1.13 kg/m]
Finish	Mill or Dark Anodized

## Sectional Properties

	CrossRail 48-XL
Sx	0.2420 in <sup>3</sup> [3.966 cm <sup>3</sup> ]
Sy	0.2140 in <sup>3</sup> [3.507 cm <sup>3</sup> ]
A [X-Section]	0.6520 in <sup>2</sup> [4.206 cm <sup>2</sup> ]

Units: [mm] in

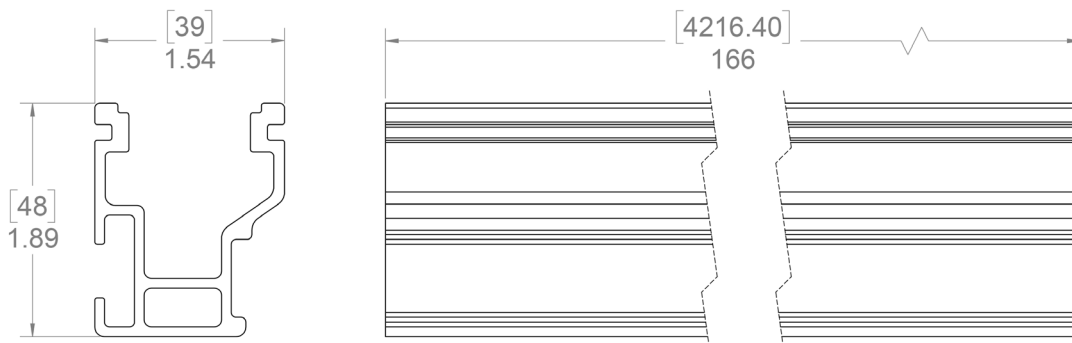

### Notes:

- ▶ Structural values and span charts determined in accordance with Aluminum Design Manual and ASCE 7-16
- ▶ UL2703 Listed System for Fire and Bonding

# CrossRail Tilt Up Installation Dimensions



The CrossRail Tilt Up System is a fully customizable solution. Figure 2 and Table 1 below provide recommended installation dimensions based upon a standard 60-cell and 72-cell PV module with 1/6 - point clamping locations. Always ensure that the dimensions are suitable for the project site.

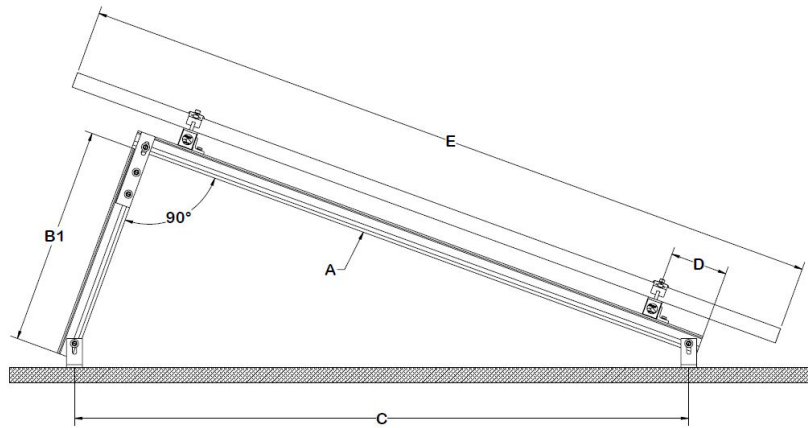

Figure 2: CrossRail Tilt Up Leg Dimensions

Dimension	Description	Desired Tilt Angle								
		15 Degrees			10 Degrees			7 Degrees		
		Portrait		Landscape	Portrait		Landscape	Portrait		Landscape
		60-Cell	72-Cell	60 & 72	60-Cell	72-Cell	60 & 72	60-Cell	72-Cell	60 & 72
A	Front Leg	54.5	62	39	54.5	62	39	54.5	62	39
B	Rear Leg	15	16.5	10	9.5	11	6.75	6.5	7.5	4.75
C	L-Foot Spacing	54	64	40	53	63	39.5	52.5	62.5	39
D	Rail Offset	5	5	5	5	5	5	5	5	5
E	Module Length	65	79	39.5	65	79	39.5	65	79	39.5
F	Rear Module Height	22	25	10	17	18	7	14	15	5
G	Front Module Height	3 1/3	3 1/3	3 1/3	3 7/8	3 7/8	3 7/8	4 1/8	4 1/8	4 1/8

Table 1: CrossRail Tilt Up installation dimensions

Note: All dimensions are in inches

\*Note: / degree tilted systems in landscape require specific configurations.

## Important Notes:

1. Rail Offset not to exceed 8 inches.
2. Rear module height not to exceed 30 inches, Note that dimension provided in Table 1 does not roof attachment height.
3. Front module height dimension does not include roof attachment height.
4. Refer to CrossRail Tilt Up Engineering Letter[s] for reaction loads at L-Feet.
5. Always refer to chosen PV module manufacturer's installation instructions for approved clamping locations. Dimensions in Table 1 assume a standard 60-cell or 72-cell module with clamping locations at the 1/6-points on the module's long edge.
6. Installer is responsible for cutting rail to lengths specified "A" and "B" in Table 1.
7. Dimensions provided in Table 1 are suggested values. Installer shall verify dimensions are appropriate for the individual site conditions, selected PV module and roof surface.
8. Adjust based on your installation needs.