

Mounting Brackets

Part Number	ID Number
MB-Q80	A3144

Bracket: Plastic
Inserts: Stainless Steel
For use with Q80 sensors:

Part No.	ID No.	Barrel Dia.	Dimensions														
			A	B	C	D	E	F	G	H	J	K	L	M	N	P	SLOT
MB-8	A3130-1	8 mm	1.26 [32.0]	0.66 [16.7]	2.00 [50.8]	1.00 [25.4]	0.45 [11.5]	0.30 [7.5]	1.41 [35.8]	0.33 [8.4]	0.06 [1.5]	0.24 [6.0]	0.67 [17.0]	0.35 [8.8]	0.83 [21.0]	.84 [21.4]	0.16 x 0.59 [4.0 x 15.0]
MB-12	A3130	12 mm	1.63 [41.5]	0.87 [22.15]	2.50 [63.5]	1.25 [31.8]	0.61 [15.5]	0.31 [7.9]	1.88 [47.8]	0.50 [12.7]	0.06 [1.5]	0.35 [9.0]	0.87 [22.0]	0.45 [11.5]	1.02 [26.0]	1.13 [28.7]	0.22 x 0.73 [5.6 x 18.6]
MB-18	A3135	18 mm	1.63 [41.5]	0.79 [20.0]	2.50 [63.5]	1.25 [31.8]	0.61 [15.5]	0.31 [7.9]	1.88 [47.8]	0.75 [19.1]	0.06 [1.5]	0.35 [9.0]	0.87 [22.0]	0.45 [11.5]	1.04 [26.3]	1.15 [29.1]	0.22 x 0.75 [5.6 x 19.0]
MB-30	A3140	30 mm	2.62 [66.5]	1.32 [33.5]	4.25 [108.0]	1.75 [44.5]	0.88 [22.4]	0.37 [9.5]	3.50 [88.9]	1.19 [30.2]	0.07 [1.8]	0.63 [16.0]	1.14 [29.0]	1.18 [30.0]	1.54 [39.0]	2.06 [52.2]	0.28 x 1.25 [7.1 x 31.8]

MB-8, MB-18 Material: 16 Gage Cold Roll Steel
MB-12, MB-30 Material: 14 Gage Cold Roll Steel
Finish: Galvanized

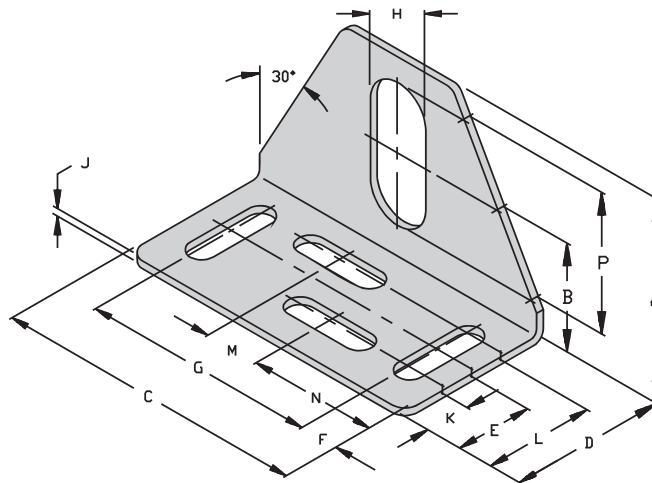

Inches [mm]