



SVX9000 Adjustable Frequency Drives

Technical Data

SVX9000 Open Drives
SVX9000 Enclosed Drives

November 2005
Supersedes June 2005

Overview

With the combination of the MVX9000 series microdrive and the SVX9000 series sensorless vector control, Eaton's expanded Cutler-Hammer® drive offering now covers a complete line of PWM adjustable frequency (speed) drives in ratings from:

- 208V — 3/4 to 100 hp CT;
1 to 100 hp VT
- 230V — 3/4 to 100 hp CT;
1 to 100 hp VT
- 480V — 1 to 1600 hp CT;
1-1/2 to 1800 hp VT
- 575V — 2 to 2000 hp CT;
3 to 2300 hp VT

A full range of enclosure types and options are available to meet a wide array of applications — from simple variable torque to more complex industrial applications such as conveyors, mixers and machine controls.

Application Description

Application Engineering

Proper selection and application of all drive system components is essential to assure that an adjustable frequency drive system will safely and reliably provide the performance required for any given application. The party responsible for the overall design and operation of the facility must make sure that qualified personnel are employed to select all components of the drive system, including appropriate safety devices. Eaton's Cutler-Hammer AF Drives Application Engineering Department is prepared to provide assistance to answer any questions about the technical capabilities of Cutler-Hammer drives.

Motor Selection

The basic requirement of motor selection is to match the torque vs. speed capability of the motor to the torque vs. speed requirement of the driven load.

Motor Torque vs. Speed Capability

As the speed of a motor is reduced below its 60 Hz base speed, motor cooling becomes less effective because of the reduced speed of the self-cooling fan. This limitation determines the maximum torque for continuous operation at any operating speed. The maximum intermittent operating torque is determined by the motor's torque vs. current characteristics and the output current capability of the adjustable frequency controller.

Multiple Motor Operation

A number of motors can be connected in parallel to a single controller. Since the frequency of the power supplied by the controller is the same for each motor, the motors will always operate at the same speed. Application Engineering assistance must be requested for all multiple motor applications to assure compliance with all controller design limitations.

Special Types of Motors

Standard NEMA Designs A and B three-phase motors are the only motors recommended for use in the majority of applications, but other types of motors are occasionally used. If the existing motor used in the application or the motor proposed for use with the drive system is a type other than NEMA Design A or B, Application Engineering assistance must be requested to make certain that the drive is properly applied.

Controller Selection

The basic requirement of controller selection is to match the output current, voltage and frequency capabilities of the controller with the requirements of the connected motor.

Output Current

The controller must be selected and applied such that the average operating motor current and horsepower do not exceed the continuous current and horsepower ratings of the controller. The intermittent operating current must not exceed the intermittent current rating of the controller.

Contents

<i>Description</i>	<i>Page</i>
SVX9000 Open Drives	
Product Description	3
Features	3
Technical Data and Specifications	4
Catalog Number Selection	5
Product Selection	6
Options	11
Accessories	12
Dimensions	13
Spare Units & Replacement Parts	30
SVX9000 Enclosed Drives	
Product Description	36
Features	36
Standards and Certifications	36
Technical Data and Specifications	37
Catalog Number Selection	38
Product Selection	43
Dimensions	46

Motor Protection

Cutler-Hammer adjustable frequency drives include electronic motor overload protection circuits that are designed to meet the requirements of NEC article 430-2 provided that only one motor is connected to the output of the controller.

Output Voltage and Frequency

When they are shipped, AF controllers are adjusted to provide a maximum output voltage and frequency equivalent to the input line voltage and frequency. The controllers can be adjusted to operate above line frequency, but a hazard of personal injury or equipment damage may exist when the motor is operated above base speed. Before adjusting the drive to operate above line frequency, make sure that the motor and the driven machinery can safely be operated at the resulting speed.

Controller Features

Operator Control and Interface Requirements

Since there are many possible configurations and many ways of achieving a specific end result, it pays to consider the operator control and interface requirements carefully. A simplified and more economical drive package can often be achieved by selecting from standard product offerings rather than specifying a custom designed configuration.

Installation Compatibility

The successful application of an AC drive requires the assurance that the drive will be compatible with the environment in which it will be installed. In planning the installation, be sure to carefully consider the heat produced by the drive, the altitude and temperature limits and the need for clean cooling air. Other important considerations include acoustical noise, vibration, electromagnetic compatibility, power quality, controller input harmonic current and power distribution equipment requirements.

Auxiliary Equipment and Accessories

Adjustable drives are generally designed to have a motor directly connected to the controller output terminals with no other equipment connected in series or parallel. Motor starters, disconnect switches, surge absorbers, dv/dt suppression circuits, output chokes, output transformers and any other equipment under consideration for installation on the output of the controller should not be installed without first requesting Application Engineering assistance. Power factor correction capacitors must never, under any circumstances, be connected at the output of the controller. They would serve no useful purpose, and they may damage the controller.

Enclosure Definitions

■ **NEMA Type 1** — Enclosures are intended for indoor use primarily to provide a degree of protection against contact with enclosed equipment and provide a degree of protection against a limited amount of falling dirt in locations where unusual service conditions do not exist. Top or side openings in the NEMA Type 1 enclosure allow for the free exchange of inside and outside air while meeting the UL rod entry and rust resistance design tests.

■ **NEMA Type 12** — Enclosures are intended for indoor use primarily to provide a degree of protection against circulating dust, falling dirt and dripping noncorrosive liquids. To meet UL drip, dust and rust resistance tests, NEMA Type 12 enclosures have no openings to allow for the exchange of inside and outside air.

■ **Chassis IP00** — Similar to Protected Chassis IP20 except power terminals are protected by plastic shielding only. Primarily intended to be mounted inside a surrounding protective enclosure.

■ **NEMA 3R** — Similar in design to NEMA Type 12 except with more stringent design and test requirements.

Motor Protection

DV/DT and Peak Motor Voltage Solutions

Today's AFD products offer significantly improved performance, but at the potential cost of motor insulation stress. The fast switching time of the IGBT devices used in newer AFDs can

cause a transmission line effect in the output power leads to the motor, leading to possibly damaging voltage levels. To meet this need, NEMA has introduced a motor in MG1, Part 31, which provides an insulation system designed to maintain normal motor life in AFD applications. For existing motors, a motor protection scheme is required for longer cable runs. Eaton offers three standard solutions for existing systems.

■ **MotoR_x**

This patented Cutler-Hammer solution provides an energy recovery system which clamps the peak motor voltage to a safe level for standard motors. This option is used when the distance between a single motor and the drive is 600 feet or less.

■ **Output Line Reactor**

This option provides an output line reactor, reducing the DV/DT of the AFD output voltage and lessening the transmission line effect, to lower the peak voltage at the motor terminals.

Product Availability Codes

The product availability codes indicate the type of facility (warehouse, Mod Center or factory) that the product will ship from and, if it is not in stock, the number of working days needed to assemble the product from receipt of the order to shipment from the designated facility. Please note that this lead-time does not include any in-transit time from our facility to your facility.

Table 1. Product Availability Codes

Codes	Description
W	Warehouse stocked item. Shipped on customer request date. If item is backordered, please check Vista/VISTALINE or contact your Customer Support Center for product availability.
F1	Factory assemble-to-order. Shipped from factory within 1 working day after receipt of order on Vista.
FA	Factory assemble-to-order. Shipped from factory within 2 – 3 working days after receipt of order on Vista.
FB	Factory assemble-to-order. Shipped from factory within 4 – 10 working days after receipt of order on Vista.
FC	Factory assemble-to-order. Shipped from factory within 11 – 15 working days after receipt of order on Vista.
FD	Factory assemble-to-order. Shipped from factory within 16 – 20 working days after receipt of order on Vista.
FP	Factory assemble-to-order. Shipped from factory on negotiated promise date.
MA	Mod Center assemble-to-order. Shipped from Mod Center within 1 – 3 working days after receipt of order on Vista.
MB	Mod Center assemble-to-order. Shipped from Mod Center within 4 – 10 working days after receipt of order on Vista.
MP	Mod Center assemble-to-order. Shipped from Mod Center on negotiated promise date.

Product availability codes contained herein for a given product may be quantity sensitive and are subject to change without notice. For the most current information, refer to the Product Identification Inquiry (PIN) screen on Vista.

SVX9000 Open Drives



SVX9000 Open Drives

Product Description

Cutler-Hammer® SVX9000 Series Adjustable Frequency Drives from Eaton's electrical business are the next generation of drives specifically engineered for today's commercial and industrial applications. The power unit makes use of the most sophisticated semiconductor technology and a highly modular construction that can be flexibly adapted to the customer's needs.

The input and output configuration (I/O) is designed with modularity in mind. The I/O is comprised of option cards, each with its own input and output configuration. The control module is designed to accept a total of five of these cards. The cards contain not only normal analog and digital inputs but also fieldbus cards.

These drives continue the tradition of robust performance, and raise the bar on features and functionality, ensuring the best solution at the right price.

Features

- Robust design — proven 500,000 hours MTBF
- Integrated 3% line reactors standard on drives from FR4 through FR9
- EMI/RFI Filters H standard up to 200 hp CT 480V, 100 hp CT 230V
- Simplified operating menu allows for typical programming changes, while programming mode provides control of everything
- Quick Start Wizard built into the programming of the drive ensures a smooth start-up
- Keypad can display up to three monitored parameters simultaneously
- LOCAL/REMOTE operation from keypad
- Copy/Paste function allows transfer of parameter settings from one drive to the next
- Standard NEMA Type 12 keypad on all drives

- The SVX can be flexibly adapted to a variety of needs using our pre-installed "Seven in One" Precision application programs consisting of:
 - Basic
 - Standard
 - Local/Remote
 - Multi Step Speed Control
 - PID Control
 - Multi-Purpose Control
 - Pump and Fan Control with Auto Change
- Additional I/O and communication cards provide plug and play functionality
- I/O connections with simple quick connection terminals
- UL Listed
- Hand-Held Auxiliary 240 Power Supply allows programming/monitoring of control module without applying full power to the drive
- Control logic can be powered from an external auxiliary control panel, internal drive functions and fieldbus if necessary
- Brake Chopper standard from:
 - 1 – 30 hp/380 – 500V
 - 3/4 – 15 hp/208 – 230V
- NEMA Type 1 and NEMA Type 12 enclosures available, Frame Sizes FR4 – FR9
- Open Chassis FR10 and greater
- NEMA Type 1 and NEMA Type 12 available in FR10 design.
- Standard option board configuration includes an A9 I/O board and an A2 relay output board installed in slots A and B

Technical Data and Specifications

Table 2. SVX9000 Specifications

Description	Specification
Input Ratings	
Input Voltage (V_{in})	+10% / -15%
Input Frequency (f_{in})	50/60 Hz (variation up to 45 – 66 Hz)
Connection to Power	Once per minute or less (typical operation)
High Withstand Rating	100 kAIC

Output Ratings	
Output Voltage	0 to V_{in}
Continuous Output Current	CT rated 100% at 122°F (50°C), FR9 and below VT rated 100% at 104°F (40°C), FR9 and below CT/VT 100% at 104°F (40°C), FR10 and above
Overload Current (CT/VT)	150% CT, 110% VT for 1 min.
Output Frequency	0 to 320 Hz
Frequency Resolution	.01 Hz
Initial Output Current (CT)	250% for 2 seconds

Control Characteristics	
Control Method	Frequency Control (V/f) Open Loop: Sensorless Vector Control, Closed Loop: SPX9000 Drives Only
Switching Frequency Frame 4 – 6 Frame 7 – 12	Adjustable with Parameter 2.6.9 1 to 16 kHz; default 10 kHz 1 to 10 kHz; default 3.6 kHz
Frequency Reference	Analog Input: Resolution .1% (10-bit), accuracy \pm 1% V/Hz Panel Reference: Resolution .01 Hz
Field Weakening Point	30 to 320 Hz
Acceleration Time	0 to 3000 sec.
Deceleration Time	0 to 3000 sec.
Braking Torque	DC brake: 30% x T_n (without brake option)

Ambient Conditions	
Ambient Operating Temperature	14°F (-10°C), no frost to 122°F (+50°C) CT 14°F (-10°C), no frost to 104°F (+40°C) VT
Storage Temperature	-40°F (-40°C) to 158°F (70°C)
Relative Humidity	0 to 95% RH, noncondensing, non-corrosive, no dripping water
Air Quality	Chemical vapors: IEC 721-3-3, unit in operation, class 3C2; Mechanical particles: IEC 721-3-3, unit in operation, class 3S2
Altitude	100% load capacity (no derating) up to 3280 ft. (1000m); 1% derating for each 328 ft. (100m) above 3280 ft. (1000m); max. 9842 ft. (3000m)
Vibration	EN 50178, EN 60068-2-6; 5 to 50 Hz, Displacement amplitude 1 mm (peak) at 3 to 15.8 Hz, Max. acceleration amplitude 1G at 15.8 to 150 Hz
Shock	EN 50178, EN 60068-2-27 UPS Drop test (for applicable UPS weights) Storage and ship- ping: max. 15G, 11 ms (in package)
Enclosure Class	NEMA 1/IP21 or NEMA 12/IP54, Open Chassis/IP20

Description	Specification
Standards	
Product	IEC 61800-2
Safety	UL 508C
EMC (at default settings)	Immunity: Fulfills all EMC immunity require- ments; Emissions: EN 61800-3, LEVEL H

Control Connections	
Analog Input Voltage	0 to 10V, R = 200 k Ω (-10 to 10V joystick con- trol) Resolution .1%; accuracy \pm 1%
Analog Input Current	0(4) to 20 mA; R_i - 250 Ω differential
Digital Inputs (6)	Positive or negative logic; 18 to 30V DC
Auxiliary Voltage	+24V \pm 15%, max. 250 mA
Output Reference Volt- age	+10V +3%, max. load 10 mA
Analog Output	0(4) to 20 mA; R_L max. 500 Ω ; Resolution 10 bit; Accuracy \pm 2%
Digital Outputs	Open collector output, 50 mA/48V
Relay Outputs	2 programmable Form C relay outputs Switching capacity: 24V DC / 8A, 250V AC / 8A, 125V DC / 0.4A

Protections	
Overcurrent Protection	Trip limit 4.0 x I_{CT} instantaneously
Overvoltage Protection	Yes
Undervoltage Protection	Yes
Earth Fault Protection	In case of earth fault in motor or motor cable, only the frequency converter is protected
Input Phase Supervision	Trips if any of the input phases are missing
Motor Phase Supervision	Trips if any of the output phases are missing
Overtemperature Protection	Yes
Motor Overload Protection	Yes
Motor Stall Protection	Yes
Motor Underload Protection	Yes
Short Circuit Protection	Yes (+24V and +10V Reference Voltages)

Table 3. Standard I/O Specifications

Description	Specification
6 – Digital Input Programmable	24V: "0" \leq 10V, "1" \geq 18V, R_i > 5 k Ω
2 – Analog Input Configurable w/Jumpers	Voltage: 0 – \pm 10V, R_i > 200 k Ω Current: 0 (4) – 20 mA, R_i = 250 k Ω
2 – Digital Output Programmable	Form C Relays 250V AC 2 Amp or 30V DC 2 Amp resistive
1 – Digital Output Programmable	Open collector 48V DC 50 mA
1 – Analog Output Programmable Configurable w/Jumper	0 – 20 mA, R_L < 500 ohms, resolution 10 Bits/0.1%

Catalog Number Selection

Table 4. Adjustable Frequency Drive Catalog Numbering System

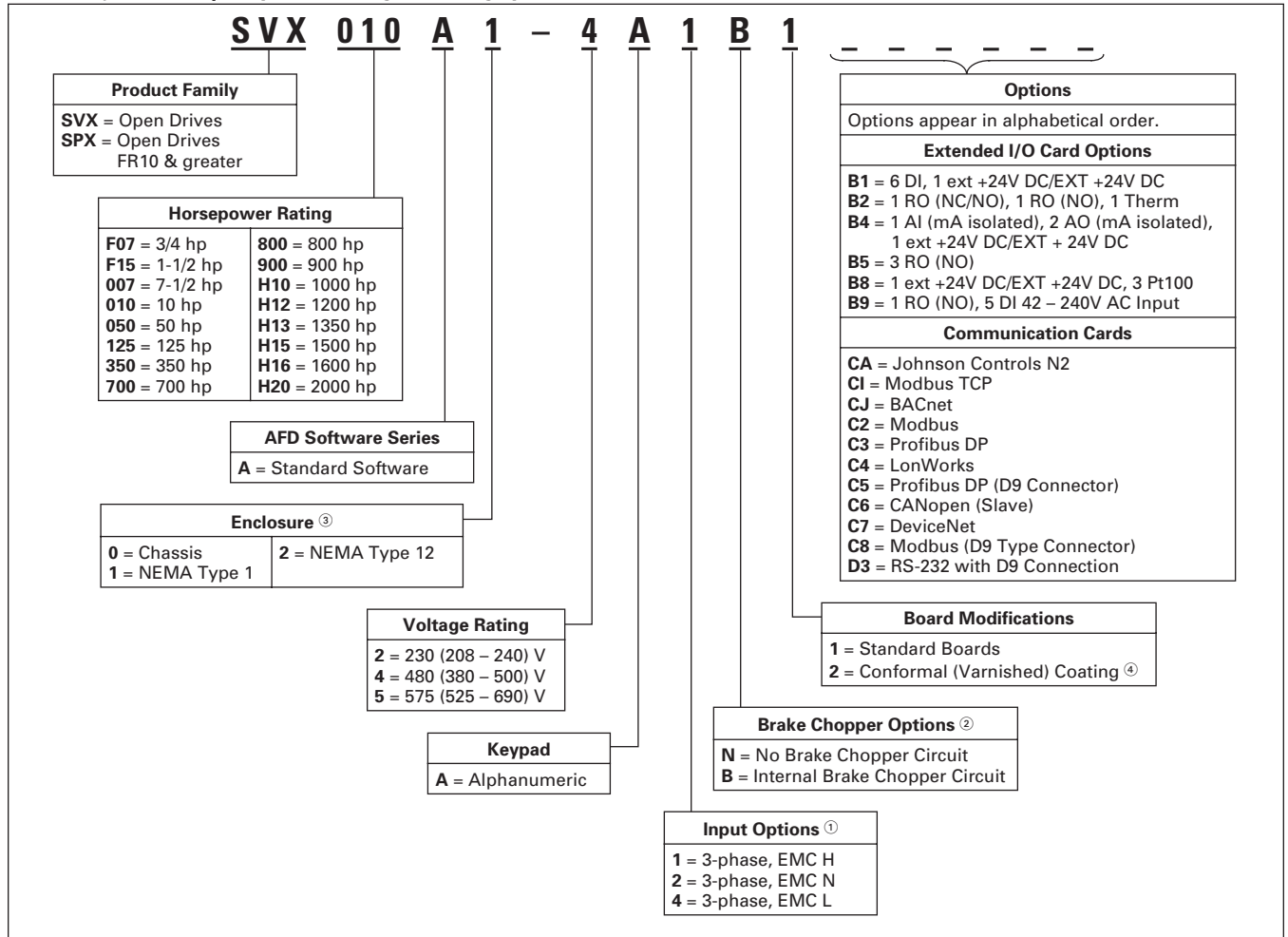

① All 230V Drives and 480V Drives up to 200 hp (CT) are only available with Input Option 1 (EMC Level H). 480V Drives 250 hp (CT) or larger are available with Input Option 2 (EMC Level N). 480V Drives are available with Input Option 4 (EMC Level L). 575V Drives 200 hp (CT) or larger are only available with Input Option 2. 575V Drives up to 150 hp (CT) are only available with Input Option 4 (EMC Level L).

② 480V Drives up to 30 hp (CT) are only available with Brake Chopper Option B. 480V Drives 40 hp (CT) or larger come standard with Brake Chopper Option N. 230V Drives up to 15 hp (CT) are only available with Brake Chopper Option B. 230V Drives 20 hp or larger come standard with Brake Chopper Option N. All 575V Drives come standard without Brake Chopper Option (N). **Note:** N = No Brake Chopper.

③ 480V Drives 250 – 350 hp (CT) are available with enclosure Style 0 (Chassis). 480V and 690V FR10 Drives are available with 1 (NEMA Type 1) or 2 (NEMA Type 12).

④ Factory promise delivery. Consult Sales Office for availability.

Product Selection

230V SVX9000 Drives

Table 5. 208 – 240V, NEMA Type 1 Drive

Frame Size	Delivery Code	hp (CT)	Current (CT)	hp (VT)	Current (VT)	Catalog Number
FR4	W	3/4	3.7	1	4.8	SVXF07A1-2A1B1
		1	4.8	1-1/2	6.6	SVX001A1-2A1B1
		1-1/2	6.6	2	7.8	SVXF15A1-2A1B1
		2	7.8	3	11	SVX002A1-2A1B1
		3	11	—	12.5	SVX003A1-2A1B1
FR5	W	—	12.5	5	17.5	SVX004A1-2A1B1
		5	17.5	7-1/2	25	SVX005A1-2A1B1
		7-1/2	25	10	31	SVX007A1-2A1B1
FR6	W	10	31	15	48	SVX010A1-2A1B1
		15	48	20	61	SVX015A1-2A1B1
FR7	W	20	61	25	75	SVX020A1-2A1N1
		25	75	30	88	SVX025A1-2A1N1
		30	88	40	114	SVX030A1-2A1N1
FR8	W	40	114	50	140	SVX040A1-2A1N1
		50	140	60	170	SVX050A1-2A1N1
		60	170	75	205	SVX060A1-2A1N1
FR9	FP	75	205	100	261	SVX075A1-2A1N1
		100	261	—	—	SVX100A1-2A1N1

Table 6. 208 – 240V, NEMA Type 12 Drive

Frame Size	Delivery Code	hp (CT)	Current (CT)	hp (VT)	Current (VT)	Catalog Number
FR4	F1	3/4	3.7	1	4.8	SVXF07A2-2A1B1
		1	4.8	1-1/2	6.6	SVX001A2-2A1B1
		1-1/2	6.6	2	7.8	SVXF15A2-2A1B1
		2	7.8	3	11	SVX002A2-2A1B1
		3	11	—	12.5	SVX003A2-2A1B1
FR5	F1	—	12.5	5	17.5	SVX004A2-2A1B1
		5	17.5	7-1/2	25	SVX005A2-2A1B1
		7-1/2	25	10	31	SVX007A2-2A1B1
FR6	F1	10	31	15	48	SVX010A2-2A1B1
		15	48	20	61	SVX015A2-2A1B1
FR7	W	20	61	25	75	SVX020A2-2A1N1
		25	75	30	88	SVX025A2-2A1N1
		30	88	40	114	SVX030A2-2A1N1
FR8	FP	40	114	50	140	SVX040A2-2A1N1
		50	140	60	170	SVX050A2-2A1N1
		60	170	75	205	SVX060A2-2A1N1
FR9	FP	75	205	100	261	SVX075A2-2A1N1
		100	261	—	—	SVX100A2-2A1N1

480V SVX9000 Drives

Table 7. 380 – 500V, NEMA Type 1 Drive

Frame Size	Delivery Code	hp (CT)	Current (CT)	hp (VT)	Current (VT)	Catalog Number
FR4	W	1	2.2	1-1/2	3.3	SVX001A1-4A1B1
		1-1/2	3.3	2	4.3	SVXF15A1-4A1B1
		2	4.3	3	5.6	SVX002A1-4A1B1
		3	5.6	5	7.6	SVX003A1-4A1B1
		5	7.6	—	9	SVX005A1-4A1B1
		—	9	7-1/2	12	SVX006A1-4A1B1
FR5	W	7-1/2	12	10	16	SVX007A1-4A1B1
		10	16	15	23	SVX010A1-4A1B1
		15	23	20	31	SVX015A1-4A1B1
FR6	W	20	31	25	38	SVX020A1-4A1B1
		25	38	30	46	SVX025A1-4A1B1
		30	46	40	61	SVX030A1-4A1B1
FR7	W	40	61	50	72	SVX040A1-4A1N1
		50	72	60	87	SVX050A1-4A1N1
		60	87	75	105	SVX060A1-4A1N1
FR8	W	75	105	100	140	SVX075A1-4A1N1
		100	140	125	170	SVX100A1-4A1N1
		125	170	150	205	SVX125A1-4A1N1
FR9	W	150	205	200	261	SVX150A1-4A1N1
		200	245	250	300	SVX200A1-4A1N1

Table 8. 380 – 500V, NEMA Type 1 Freestanding Drive

Frame Size	Delivery Code	hp (CT)	Current (CT)	hp (VT)	Current (VT)	Catalog Number
FR10	W	250	330	300	385	SPX250A1-4A4N1
	FP	300	385	350	460	SPX300A1-4A4N1
	W	350	460	400	520	SPX350A1-4A4N1
FR11	FP	400	520	500	590	SPX400A1-4A4N1
	FP	500	590	550	650	SPX500A1-4A4N1
	FP	550	650	600	730	SPX550A1-4A4N1

Note: Integrated fuses as standard. Limited option selection available; 115V Transformer (KB), Light Kit (L1), HOA (K4), Speed Potentiometer w/HOA (K2), Disconnect Switch (P2). See Enclosed 480V option selection for pricing.

Table 9. 380 – 500V, NEMA Type 12 Drive

Frame Size	Delivery Code	hp (CT)	Current (CT)	hp (VT)	Current (VT)	Catalog Number
FR4	F1	1	2.2	1-1/2	3.3	SVX001A2-4A1B1
		1-1/2	3.3	2	4.3	SVXF15A2-4A1B1
		2	4.3	3	5.6	SVX002A2-4A1B1
		3	5.6	5	7.6	SVX003A2-4A1B1
		5	7.6	—	9	SVX005A2-4A1B1
		—	9	7-1/2	12	SVX006A2-4A1B1
FR5	F1	7-1/2	12	10	16	SVX007A2-4A1B1
		10	16	15	23	SVX010A2-4A1B1
		15	23	20	31	SVX015A2-4A1B1
FR6	F1	20	31	25	38	SVX020A2-4A1B1
		25	38	30	46	SVX025A2-4A1B1
		30	46	40	61	SVX030A2-4A1B1
FR7	W	40	61	50	72	SVX040A2-4A1N1
		50	72	60	87	SVX050A2-4A1N1
		60	87	75	105	SVX060A2-4A1N1
FR8	W	75	105	100	140	SVX075A2-4A1N1
		100	140	125	170	SVX100A2-4A1N1
		125	170	150	205	SVX125A2-4A1N1
FR9	W	150	205	200	261	SVX150A2-4A1N1
		200	245	250	300	SVX200A2-4A1N1

Table 10. 380 – 500V, NEMA Type 12 Freestanding Drive

Frame Size	Delivery Code	hp (CT)	Current (CT)	hp (VT)	Current (VT)	Catalog Number
FR10	FP	250	330	300	385	SPX250A2-4A4N1
	FP	300	385	350	460	SPX300A2-4A4N1
	FP	350	460	400	520	SPX350A2-4A4N1

Note: Integrated fuses as standard. Limited option selection available; 115V Transformer (KB), Light Kit (L1), HOA (K4), Speed Potentiometer w/HOA (K2), Disconnect Switch (P2). See Enclosed 480V option selection for pricing.

Table 11. 480V 380 – 500, Open Chassis Drive

Frame Size	Delivery Code	hp (CT)	Current (CT)	hp (VT)	Current (VT)	Catalog Number
FR10 ①	W	250	330	300	385	SPX250A0-4A2N1
		300	385	350	460	SPX300A0-4A2N1
		350	460	400	520	SPX350A0-4A2N1
FR11	FP	400	520	500	590	SPX400A0-4A2N1
		500	590	—	650	SPX500A0-4A2N1
		—	650	600	730	SPX550A0-4A2N1
FR12	FP	600	730	—	820	SPX600A0-4A2N1
		—	820	700	920	SPX650A0-4A2N1
		700	920	800	1030	SPX700A0-4A2N1
FR13	FP	800	1030	900	1150	SPX800A0-4A2N1
		900	1150	1000	1300	SPX900A0-4A2N1
		1000	1300	1200	1450	SPXH10A0-4A2N1
FR14	FP	1200	1600	1500	1770	SPXH12A0-4A2N1
		1600	1940	1800	2150	SPXH16A0-4A2N1

① FR10 – FR14 includes 3% line reactor, but it is not integral to chassis.

575V SVX9000 Drives

Table 12. 525 – 690V, NEMA Type 1 Drive

Frame Size	Delivery Code	hp (CT)	Current (CT)	hp (VT)	Current (VT)	Catalog Number
FR6	W	2	3.33	3	4.5	SVX002A1-5A4N1
		3	4.5	—	5.5	SVX003A1-5A4N1
		—	5.5	5	7.5	SVX004A1-5A4N1
		5	7.5	7-1/2	10	SVX005A1-5A4N1
		7-1/2	10	10	13.5	SVX007A1-5A4N1
		10	13.5	15	18	SVX010A1-5A4N1
		15	18	20	22	SVX015A1-5A4N1
		20	22	25	27	SVX020A1-5A4N1
		25	27	30	34	SVX025A1-5A4N1
FR7	W	30	34	40	41	SVX030A1-5A4N1
		40	41	50	52	SVX040A1-5A4N1
FR8	W	50	52	60	62	SVX050A1-5A4N1
		60	62	75	80	SVX060A1-5A4N1
		75	80	100	100	SVX075A1-5A4N1
FR9	W	100	100	125	125	SVX100A1-5A4N1
		125	125	150	144	SVX125A1-5A4N1
		150	144	—	170	SVX150A1-5A4N1
		—	170	200	208	SVX175A1-5A4N1

Table 13. 525 – 690V, NEMA Type 1 Freestanding Drive

Frame Size	Delivery Code	hp (CT)	Current (CT)	hp (VT)	Current (VT)	Catalog Number
FR10	FP	200	208	250	261	SPX200A1-5A4N1
		250	261	300	325	SPX250A1-5A4N1
		300	325	400	385	SPX300A1-5A4N1
FR11	FP	400	385	450	460	SPX400A1-5A4N1
		450	460	500	502	SPX450A1-5A4N1
		500	502	550	590	SPX500A1-5A4N1

Note: Integrated fuses as standard. Limited option selection available; 115V Transformer (KB), Light Kit (L1), HOA (K4), Speed Potentiometer w/HOA (K2), Disconnect Switch (P2). See Enclosed 480V option selection for pricing.

Table 14. 525 – 690V, NEMA Type 12 Drive

Frame Size	Delivery Code	hp (CT)	Current (CT)	hp (VT)	Current (VT)	Catalog Number
FR6	F1	2	3.33	3	4.5	SVX002A2-5A4N1
		3	4.5	—	5.5	SVX003A2-5A4N1
		—	5.5	5	7.5	SVX004A2-5A4N1
		5	7.5	7-1/2	10	SVX005A2-5A4N1
		7-1/2	10	10	13.5	SVX007A2-5A4N1
		10	13.5	15	18	SVX010A2-5A4N1
		15	18	20	22	SVX015A2-5A4N1
		20	22	25	27	SVX020A2-5A4N1
		25	27	30	34	SVX025A2-5A4N1
FR7	FP	30	34	40	41	SVX030A2-5A4N1
		40	41	50	52	SVX040A2-5A4N1
FR8	FP	50	52	60	62	SVX050A2-5A4N1
		60	62	75	80	SVX060A2-5A4N1
		75	80	100	100	SVX075A2-5A4N1
FR9	FP	100	100	125	125	SVX100A2-5A4N1
		125	125	150	144	SVX125A2-5A4N1
		150	144	—	170	SVX150A2-5A4N1
		—	170	200	208	SVX175A2-5A4N1

Dimensions

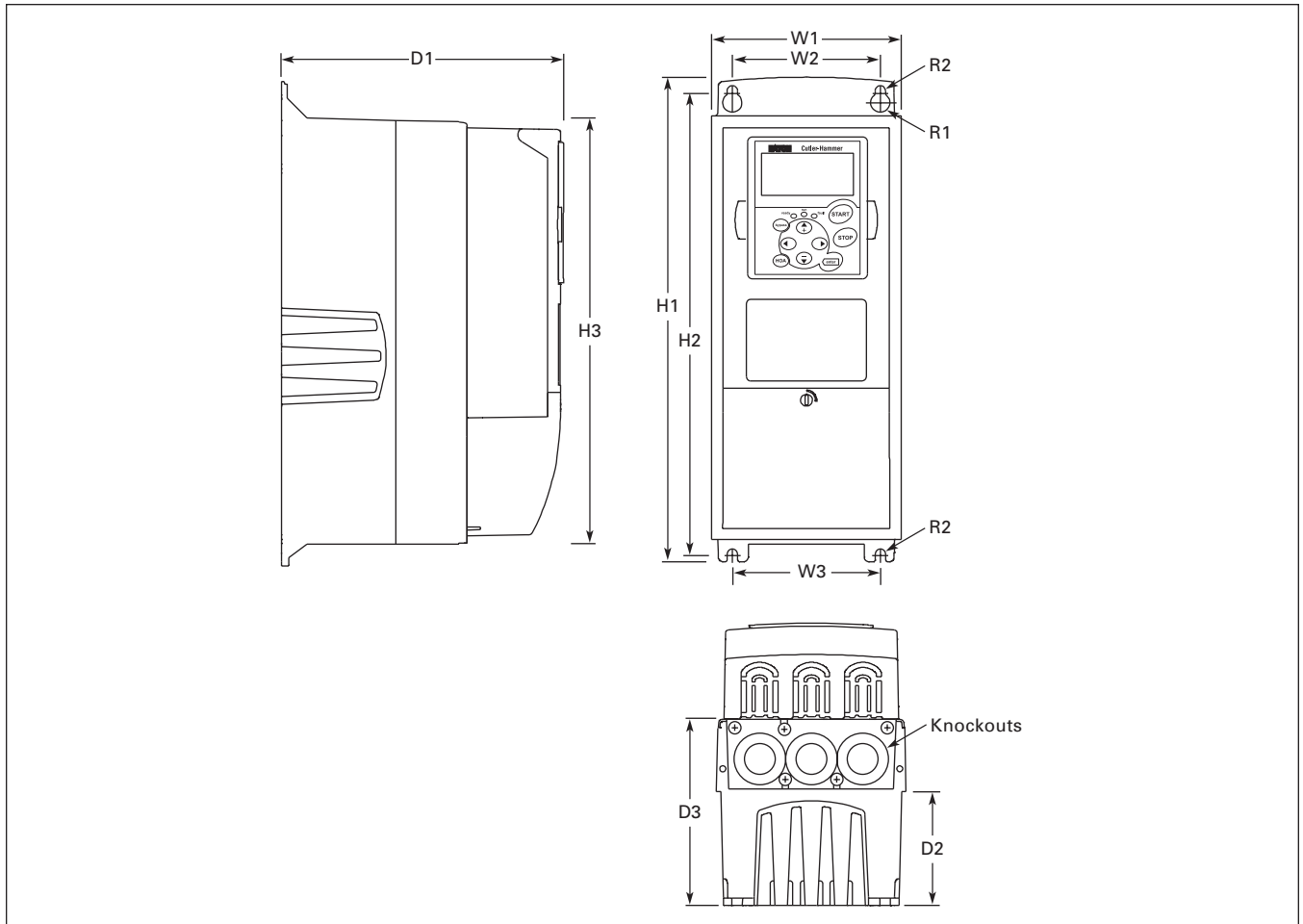

Figure 2. NEMA Type 1 and NEMA Type 12 9000X Drive Dimensions, FR4, FR5 and FR6

Table 25. 9000X Drive Dimensions

Frame Size	Voltage	hp (CT)	Approximate Dimensions in Inches (mm)										Weight Lbs. (kg)	Knockouts @ Inches (mm) N1 (O.D.)	
			H1	H2	H3	D1	D2	D3	W1	W2	W3	R1 dia.			R2 dia.
FR4	230V	3/4 – 3	12.9	12.3	11.5	7.5	3.0	5.0	5.0	3.9	—	.5	.3	11.0	3 @ 1.1
	480V	1 – 5	(327)	(313)	(292)	(190)	(77)	(126)	(128)	(100)		(13)	(7)	(5)	(28)
FR5	230V	5 – 7-1/2	16.5	16.0	15.3	8.4	3.9	5.8	5.6	3.9	—	.5	.3	17.9	2 @ 1.5
	480V	7-1/2 – 15	(419)	(406)	(389)	(214)	(100)	(148)	(143)	(100)		(13)	(7)	(8)	(37) 1 @ 1.1 (28)
FR6	230V	10 – 15	22.0	21.3	20.4	9.3	4.2	6.5	7.6	5.8	—	.6	.4	40.8	3 @ 1.5
	480V	20 – 30	(558)	(541)	(519)	(237)	(105)	(165)	(195)	(148)		(15.5)	(9)	(19)	(37)
	575V	2 – 25													

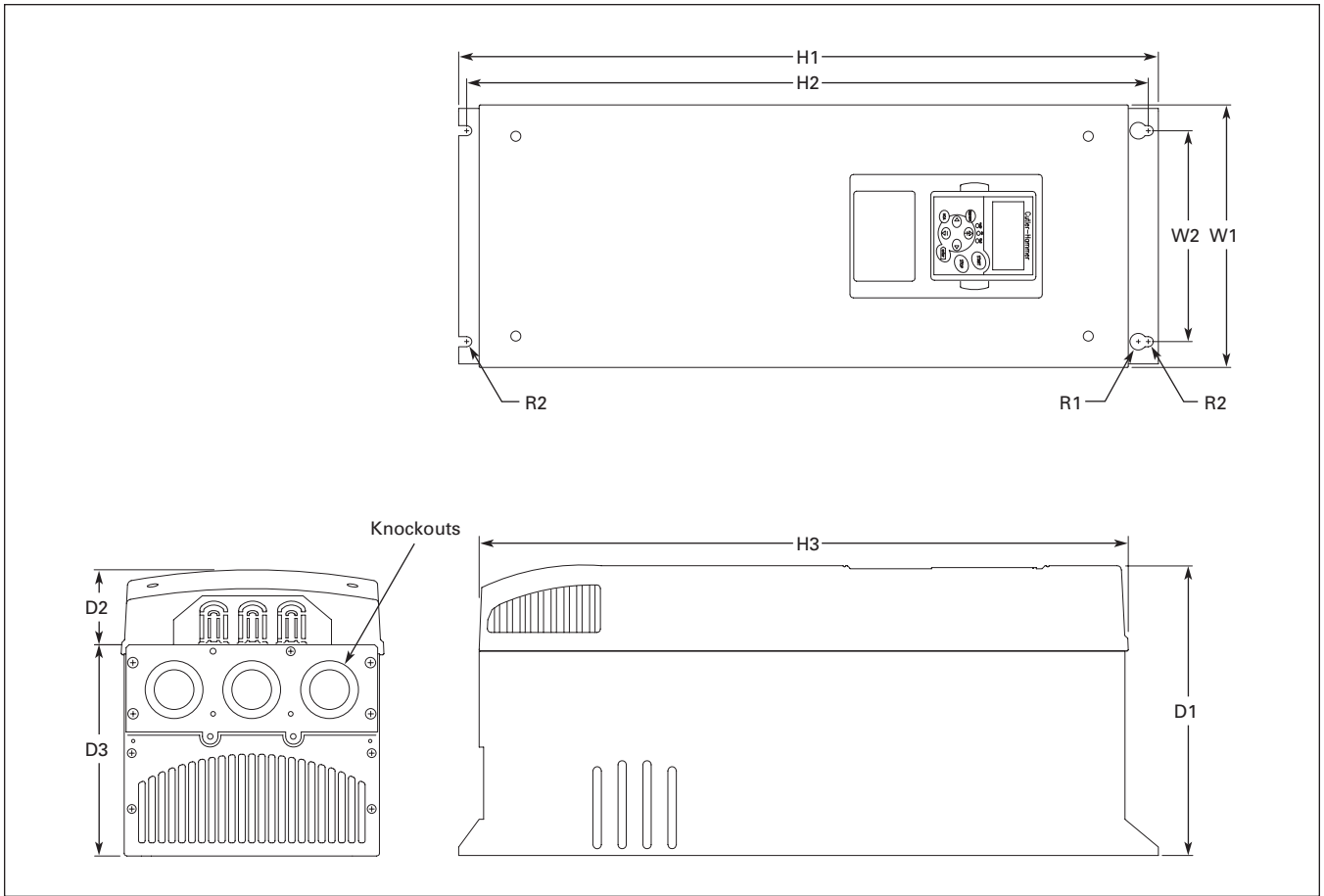

Figure 4. 9000X Dimensions, NEMA Type 1 and NEMA Type 12, FR7

Table 28. 9000X Drive Dimensions, FR7

Frame Size	Voltage	hp (CT)	Approximate Dimensions in Inches (mm)										Weight lbs. (kg)	Knockouts @ Inches (mm) N1 (O.D.)
			H1	H2	H3	D1	D2	D3	W1	W2	R1 dia.	R2 dia.		
FR7	230V	20 – 30	24.8	24.2	23.2	10.1	3.0	7.3	9.3	7.5	.7	.4	77.2	3 @ 1.5 (37)
	480V	40 – 60	(630)	(614)	(590)	(257)	(77)	(184)	(237)	(190)	(18)	(9)	(35)	
	575V	30 – 40												