



Approvals



GAM T1 listed

Life expectancy

L-10 LIFE AT 40°C:

80 000 hours (ball bearings)

50 000 hours (sleeve bearings)

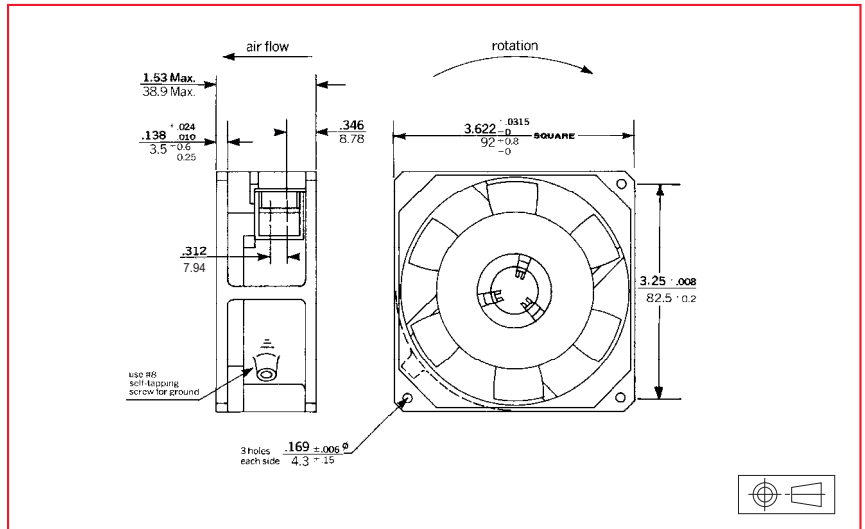

AC Motor

Electrical protection: impedance protected

Housing material: zamak

Impeller material: plastic UL 94 VO

Weight: 0,615 kg

Available with:

- flying leads

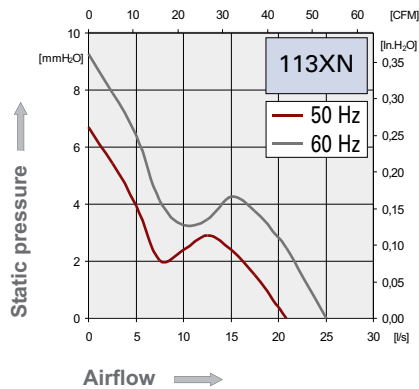

Part number	Nominal voltage	Airflow	Noise level	Nominal speed	Frequency	Phases	Capacitor	Input power	Nominal current	Starting current	Bearing system		Connection type		Operating temperature	
	V	l/s	dB(A)	RPM	Hz		µF	W	mA	mA	Ball	Sleeve	Leads	Terminals	Min. °C	Max. °C
113XN0182000	115	21	36	2850	50	1		10	140	270	X			X	- 10	70
		25	41	3300	60	1		9	115	220	X			X	- 10	70
113XN0181000	208-240	21	36	2850	50	1		12	85	160	X			X	- 10	70
		25	41	3300	60	1		11	75	140	X			X	- 10	70

Additional versions:

Salt spray protected; shock and vibration protected -

Marine specifications; wide temperature range

Accessories:

- Plastic finger guards P/N : PFG-92 and 91-53

- Plastic filter P/N : F90/T102

- Rubber mounts P/N : AM-10

- Metal finger guard P/N : 9901-43

- Metal mesh filter P/N : 90-G