

Sealing Boots for Rocker-Style Circuit Breakers

E-SEEL® (Rock-R-Seel™) boots for rocker-style circuit breakers are made of RUBRGLAS™, APM's proprietary high tear-strength, transparent silicone rubber. These durable and flexible boots lock out dust, dirt, and moisture ... without compromising circuit breaker operability, position status viewing or legend visibility. Each is designed to fully enclose the breaker bezel, while our unique molded-in "panel sealing rib" forms a water resistant and dust-tight seal against the front panel surface.

SPECIFICATIONS

Material.....APM RUBRGLAS™ (transparent silicone rubber), polymer type, ASTM D1418
Temperature Range....-80°F to +400°F
Operational Life.....50,000 actuations (minimum)
Resistant to.....Salt spray, sunlight, ozone, weather, fungus, and most acids and lubricating oils
Agency Recognition...UL-Recognized to UL Std. 50, Types 1, 2, 3R, 5, 12(K) & 13. UL Recognition also includes compliance with Canadian National Standards.
Shelf Life.....Excess of 25 years

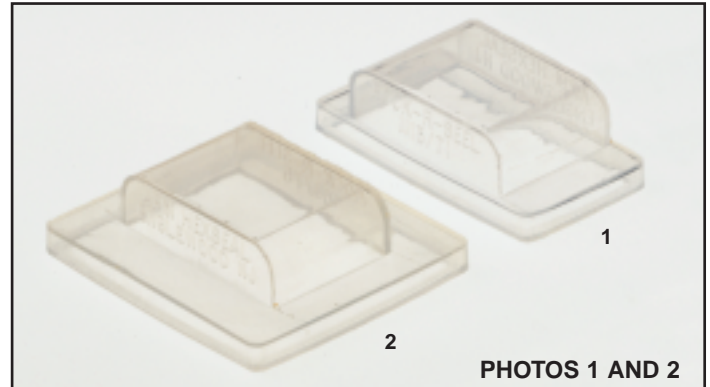

HOW TO ORDER

Specify APM boot part number.

Photo #	E-SEEL Part #	Dimensions										IP Rating	Compatible with These Manufacturers (Partial List)
		A		B		C		D		E			
		in.	mm	in.	mm	in.	mm	in.	mm	in.	mm		
1	C1113/71	.413	10.49	.687	17.46	1.046	26.59	1.327	36.51	.703	17.86	IP55	Carling Technologies M Series Airpax R11 Eaton/Heinemann LC-1
2	C1113/75	.413	10.49	.687	17.46	1.046	26.59	1.437	36.51	1.390	35.32	IP55	Carling Technologies M Series Airpax R21 Eaton/Heinemann LC-2

NOTE: Other rocker-style switch and circuit breaker boots are available. Please consult factory.

FIGURE 10

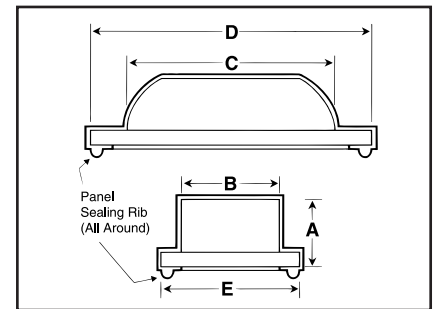

Rocker-Actuated Front Panel Mounted Boots

IP66/68 Rated

APM Part No.	No. of Poles	Height	L1	L2	L3	W1	W2	Slotted SEELSKREWS Provided	Compatible with these manufacturers		
									Airpax	Carling	Heinemann
HE1010 (Fig. 11)	1	0.45	1.30	1.09	1.66	0.80	1.20	2 ea #6-32x3/8	IAGBX, IUGBX, IEGBX, IALBX, IULBX, IELBX		
HE1045 (Fig. 12)	1	0.45	1.30	1.90	1.66	0.80	1.20	2 ea #6-32x3/8	IALZX, IULZX, IELZX, IMLZX, IAGZX, IUGZX, IEGZX	AC, AF, CC, CF	JCS

NOTE: Assembly consists of Boot, Frame, and Seelscrew self-sealing mounting screws.

DIMENSIONS FOR REFERENCE ONLY.

Current dimensional drawings can be viewed on our website and CAD drawings can also be downloaded.

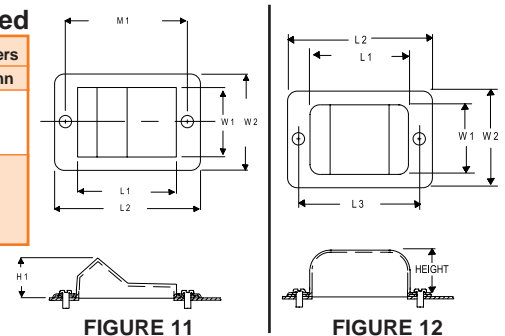

Qualified Products List

The following standard APM HEXSEALS are QPL-Listed, per QPL5423. Other QPL-listed products are available. Please consult factory.

Lever-Actuated Circuit Breaker Boots

Military P/N	APM P/N	Page
M5423/13-01	HE1076	8, 9
M5423/13-02	HE1077	8, 9
M5423/13-03	HE1075/3	8, 9
M5423/14-01	HE1040	8, 9
M5423/14-02	HE1035	8, 9
M5423/14-03	HE1070	8, 9
M5423/14-04	HE1080	8, 9
M5423/14-05	HE1015	8, 9

Lever-Actuated Circuit Breaker Boots

Military P/N	APM P/N	Page
M5423/14-05T	HE1015T	8, 9
M5423/14-06	HE1020	8, 9
M5423/14-06T	HE1020T	8, 9
M5423/14-07	HE1050	8, 9
M5423/14-07T	HE1050T	8, 9
M5423/14-08	1113/26	8, 9
M5423/14-08T	1113/26T	8, 9
MIL-C-17361		
AQB-A50 AQB-A101	1077	8, 9

Toggle-Actuated Circuit Breaker Boots

Military P/N	APM P/N	Page
M5423/01-01	N1030	11
M5423/02-01	N1030B	11

Pushbutton-Actuated Circuit Breaker Boots

Military P/N	APM P/N	Page
M5423/07-01	N3030	12
M5423/07-11	N3030-2513	12
M5423/07-02	NC3030	12
M5423/07-12	NC3030-2513	12
M5423/07-03	NH3030	12
M5423/07-05	NH3030S	12

Sealed Switch Sealing Bushings

Military P/N	APM P/N	Page
M5423/16-01	60064	10
M5423/16-01	60225	10