



TYPE NA

TERMINAL

FOR COPPER TUBE TO FLAT

High copper alloy terminal for joining copper tube to a flat pad. Letter "N" on end of catalog number indicates pad drilled to NEMA standards. One-wrench installation.

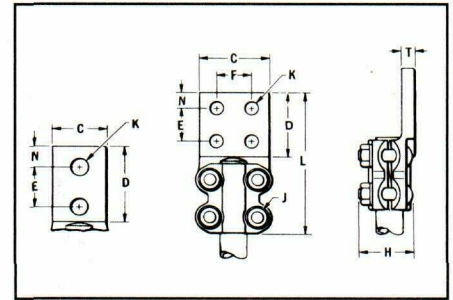
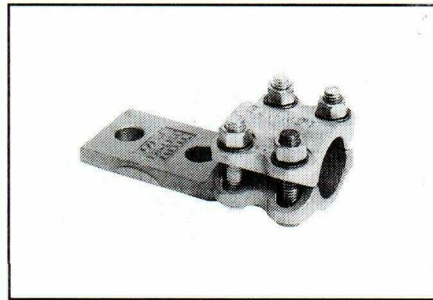

CATALOG NUMBER	CONDUCTOR	NO. OF HOLES IN PAD	C	D	E&F	H	J	K	L	N	T
NA13-2N	1/2	2	1-1/2	3	1-3/4	1-3/4	3/8	9/16	5-1/4	5/8	3/8
NA14-2N	3/4	2	1-5/8			2	3/8				3/8
NA15-2N	1	2	1-7/8			2-1/8	3/8				3/8
NA15-4N	1	4	3			2-1/8	3/8				3/8
NA16-2N	1-1/4	2	2-1/4			2-5/8	1/2				1/2
NA16-4N	1-1/4	4	3			2-5/8	1/2				1/2
NA17-2N	1-1/2	2	2-1/2			2-3/4	1/2	1/2	6	5/8	1/2
NA17-4N	1-1/2	4	3			2-3/4	1/2	1/2			
NA18-4N	2	4	3-1/8			3-1/	1/2	1/2	6-5/8	5/8	1/2
NA19-4N	2-1/2	4	3-1/4			3-3/4	1/2	1/2			
NA20-4N	3	4	4-3/8			4-3/8	5/8	3/4	7/8	5/8	3/4
NA21-4N	3-1/2	4	4-3/8			5	5/8	7/8			
NA22-4N	4	4	5-1/4			5-1/2	5/8	7/8			

TYPE XA

EXPANSION TERMINAL

FOR COPPER TUBE TO FLAT

High copper alloy expansion terminal for tube to flat. Provides for longitudinal movement of tubing. Extra flexible braid carries full load of joint. One-wrench installation.

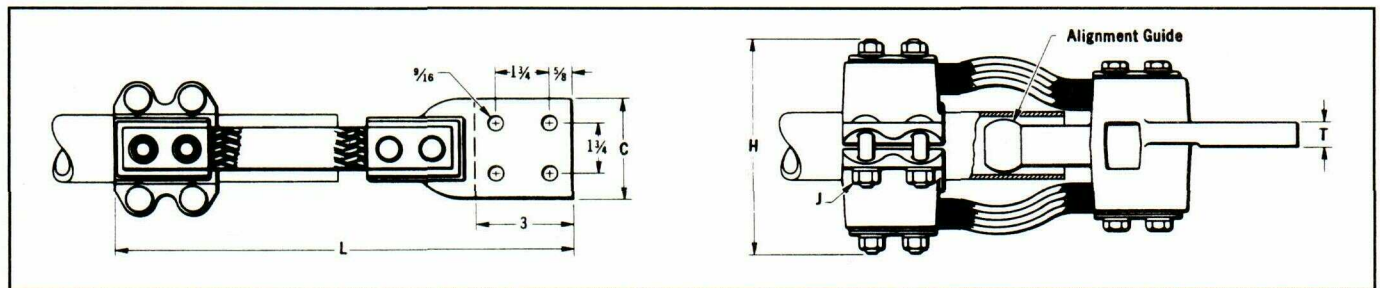
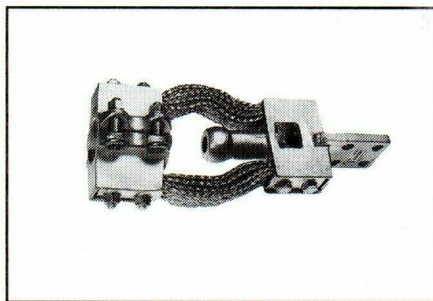

Catalog Number	Standard I.P.S.						
With Guide	Conductor	Number of Holes in Pad*	C	H	J	L	T
XA18-4N	2	4	3	7	1/2	15-1/4	1/2
XA19-4N	2-1/2		3-3/4	7-1/2		16-1/8	5/8
XA20-4N	3		4-3/8	8	5/8	16-3/4	3/4
XA-21-4N	3-1/2		4-3/4	8-1/4		17	7/8
XA22-4N	4		5-1/4	9-1/2		17	7/8

* Conforms to NEMA Standards