

# BR30 Series

LED Reflector Lamps

## Product Description

At Cree®, we believe in better lighting. Better light is beautiful light. But it's more than just beautiful. It is light that makes you feel more productive, more relaxed and safer. Better light changes everything. That's why the new and improved Cree LED bulbs feature high color rendering that enhances your space and makes the colors of your décor appear vibrant, richer and more natural – true colors the way they are meant to be experienced.

The Cree LED BR30 flood light casts a beautiful light that looks and lights like the incandescent bulbs you love. Dimmable with most standard dimmers, Cree LED BR30 flood lights shine wide and bright while using at least 88% less energy, and are designed to deliver up to 35,000 hours of light for your home or business. The perfect replacement for incandescent bulbs in track and recessed fixtures at a price you can afford, Cree LED bulbs pay for themselves quickly and then pay you year after year.

## Performance Summary

**Lamp Delivered Light Output:** 665-1,600 lumens

**Input Power:** 7-8 watts (65W equivalent), 15-16.5 watts (100W equivalent)

**CRI:** 85 CRI (65W equivalent), 90 CRI (100W equivalent)

**CCT:** 2700K, 5000K

**Limited Warranty\*:** 5 years Commercial use

**Lifetime:** Designed to last at least 35,000 hours (65W equivalent) or 25,000 hours (100W equivalent)

**Dimming:** Dimmable to 5% with select dimmers

ENERGY STAR® Certified

Must order in multiples of master carton (MC) quantities; MC = (12) Single-Lamp Cartons

\*See <http://lighting.cree.com/warranty> for warranty terms

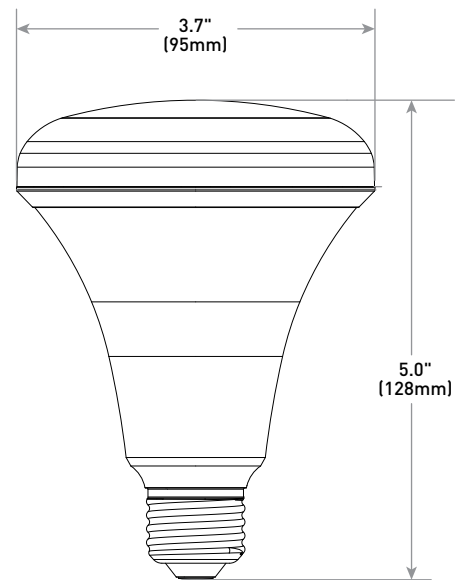

## Ordering Information

Example: BR30-65W-27K-U1

BR30						U1
Product	Watt Equivalent	CCT	Voltage	Base	CRI	Packaging Options
BR30	65W 65 Watt, 665-670 lumens 100W 100 Watt, 1500-1600 lumens	27K 2700K 50K 5000K	Blank 120 Volt	Blank E26 (screw base)	Blank 85 CRI (65W equivalent); 90 CRI (100W equivalent)	U1 Single-Lamp Carton Master Carton = (12) Single-Lamp Cartons



US: [lighting.cree.com](http://lighting.cree.com)

T (800) 236-6800 F (262) 504-5415

Rev. Date: V11 07/20/2017

Canada: [www.cree.com/canada](http://www.cree.com/canada)



T (800) 473-1234 F (800) 890-7507

## BR30 Series LED Reflector Lamps

### Product Specifications

#### CONSTRUCTION & MATERIALS

- BR30 reflector bulb design
- 65W equivalent weighs 5.6 ounces (159g); 100W equivalent weighs 10.4 ounces (294g)
- Reflector bulb meets ANSI standards for BR30 dimensions
- Uses a standard E26 screw base
- Mercury free
- **Dimensions:** 5.0" H x 3.75" W x 3.75" D (Single-Lamp Carton); 6.0" H x 12.0" W x 15.75" D (Master Carton)

#### OPTICAL SYSTEM

- Plastic lens offers increased optical spread

#### ELECTRICAL SYSTEM

- **Power Factor:** > 0.9 nominal
- **Input Voltage:** 120V, 60Hz
- **Dimming:** Dimmable to 5% with select dimmers. Refer to <https://www.cree.com/viewcontent.asp?qv=1&docid=5344> for additional details
- **Operating Temperature Range:** -25°C - +45°C (-13°F - +113°F)

#### REGULATORY & VOLUNTARY QUALIFICATIONS

- cULus Listed
- Suitable for damp locations, but not for use where exposed directly to weather or water
- Suitable for use in enclosed light fixtures. Lifetime may be reduced if used in air tight enclosures or in insulated ceiling air tight (ICAT) recessed downlight enclosures
- ENERGY STAR® certified. Please refer to <http://www.energystar.gov/productfinder/product/certified-light-bulbs/> results for most current information  
BR30-65W-27K-U1  
BR30-65W-50K-U1  
BR30-100W-27K-U1  
BR30-100W-50K-U1
- Meets FCC Part 15, Subpart B, Class B standards for conducted and radiated emissions
- RoHS compliant. Consult factory for additional details

### Packaging

(12) Single-Lamp Cartons in Master Carton (12 Total Lamps)



Ordering Number	Single-Lamp Carton UPC	Description	Bulb Type	Watts	CCT	Single-Lamp Cartons per Master Carton	Master Carton ITF-14	Total Lamps per Master Carton	Master Cartons per Pallet Qty	CRI	Lumens	Rated Life (Hrs)
BR30-65W-27K-U1	849665017622	65W Soft White BR30 Equivalent	BR30	8	2700K	12	10849665017629	12	63	85	665	35,000
BR30-65W-50K-U1	849665017639	65W Daylight BR30 Equivalent	BR30	7	5000K	12	10849665017636	12	63	85	670	35,000
BR30-100W-27K-U1	849665019022	100W Soft White BR30 Equivalent	BR30	16.5	2700K	12	10849665019029	12	63	90	1500	25,000
BR30-100W-50K-U1	849665019039	100W Daylight BR30 Equivalent	BR30	15	5000K	12	10849665019036	12	63	90	1600	25,000