

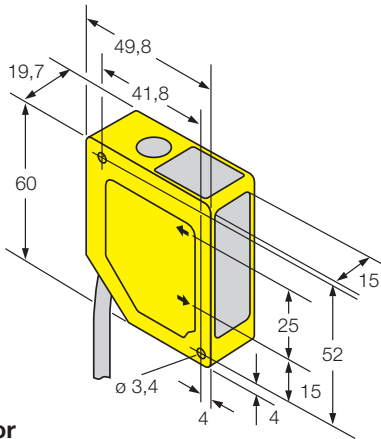

L-GAGE™ Q50 Series with complementary discrete outputs

Dimensions [mm]

● Cable



● Connector

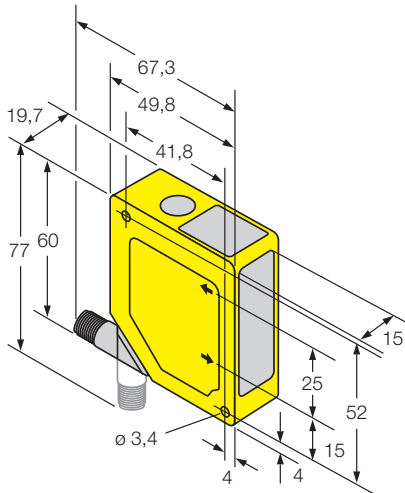

Wiring

pnp

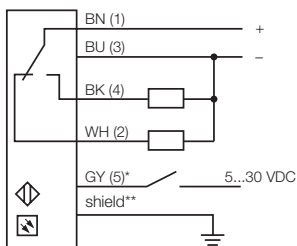

npn

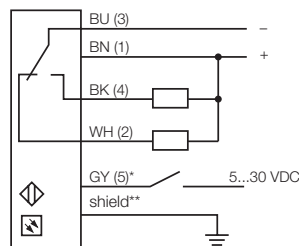

* remote programming
** cabled models only

Wave length

Red	685 nm (Q50...V)
IR (infrared)	880 nm (Q50A, Q50B)
Beam size	ø 20 mm max.

Adjustments

sensing window limits

Supply

Supply voltage	12...30 VDC
Ripple V_{pp}	≤ 10 %
No load current	≤ 70 mA
Delay upon power up	2 s

Protection

reverse polarity
transient voltages
false pulse on power-up
continuous overload
short circuit of outputs

Output

Complementary	windows or single point, programmable
Continuous load current	≤ 150 mA per output
Output response time – fast	4 ms ON, 4 ms OFF
Output response time – slow	48 ms ON, 48 ms OFF

Material

Housing	moulded ABS/polycarbonate
Lens	acrylic
Protection class (IEC 60529/EN 60529)	IP67
Temperature range	-10...+55 °C
Cable	2 m, PVC 5 x 0,5 mm ²
Connector	eurocon (M12 x 1) (rotatable)

Range Indicator LED (Bi-colour green/red)

Green	target in sensing range
Green flashing	outputs overloaded
Red	target out of sensing range
OFF	sensor power OFF

Teach Indicator LED (Bi-colour yellow/red)

Yellow (window limits)	target within taught limits
Yellow (fixed field)	target closer than cut-off limit
Red	sensor in TEACH mode
OFF	target outside of taught limits

Accessories

Brackets

SMBQ50	30 662 26	right-angle bracket
--------	-----------	---------------------

Connectors

WAKS4.5-2/S90	80 066 62	straight type
WAKS4.5-5/S90	80 066 63	right-angled type

L-GAGE™ Q50

with complementary discrete outputs

Cut-off point deviation curves
Hysteresis (mm) versus position (mm)

	Max. Range [mm]	Light source	Response time	Output function	Connection	Type	Ident number
Q50A* 	50...150	red	48 ms	pnp	cable	Q50AVP	30 638 86
	50...150	red	48 ms	pnp	connector	Q50AVPQ	30 638 87
	50...150	red	4 ms	pnp	cable	Q50AVPY	30 638 89
	50...150	red	4 ms	pnp	connector	Q50AVPYQ	30 638 90
	50...150	red	48 ms	npn	cable	Q50AVN	30 638 74
	50...150	red	48 ms	npn	connector	Q50AVNQ	30 638 75
	50...150	red	4 ms	npn	cable	Q50AVNY	30 638 77
	50...150	red	4 ms	npn	connector	Q50AVNYQ	30 638 78
	50...200	IR	48 ms	pnp	cable	Q50AP	30 676 15
	50...200	IR	48 ms	pnp	connector	Q50APQ	30 676 16
Q50B slow 	50...200	IR	4 ms	pnp	cable	Q50APY	30 676 18
	50...200	IR	4 ms	pnp	connector	Q50APYQ	30 676 19
	50...200	IR	48 ms	npn	cable	Q50AN	30 676 09
	50...200	IR	48 ms	npn	connector	Q50ANQ	30 676 10
	50...200	IR	4 ms	npn	cable	Q50ANY	30 676 12
	50...200	IR	4 ms	npn	connector	Q50ANYQ	30 676 13
	100...300	red	48 ms	pnp	cable	Q50BVP	30 652 85
	100...300	red	48 ms	pnp	connector	Q50BVPQ	30 652 86
	100...300	red	4 ms	pnp	cable	Q50BVPY	30 652 88
	100...300	red	4 ms	pnp	connector	Q50BVPYQ	30 652 89
Q50B fast 	100...300	red	48 ms	npn	cable	Q50BVN	30 652 79
	100...300	red	48 ms	npn	connector	Q50BVNQ	30 652 80
	100...300	red	4 ms	npn	cable	Q50BVNY	30 652 82
	100...300	red	4 ms	npn	connector	Q50BVNYQ	30 652 83
	100...400	IR	48 ms	pnp	cable	Q50BP	30 638 92
	100...400	IR	48 ms	pnp	connector	Q50BPQ	30 638 93
	100...400	IR	4 ms	pnp	cable	Q50BPY	30 638 95
	100...400	IR	4 ms	pnp	connector	Q50BPYQ	30 638 96
	100...400	IR	48 ms	npn	cable	Q50BN	30 638 80
	100...400	IR	48 ms	npn	connector	Q50BNQ	30 638 81
100...400	IR	4 ms	npn	cable	Q50BNY	30 638 83	
100...400	IR	4 ms	npn	connector	Q50BNYQ	30 638 84	

* Surface colour does not affect hysteresis (6 % black to 90 % white reflectance surfaces).

Colour sensitivity curves

The colour sensitivity is independent of the response time. The colour sensitivity represents the expected change in output when the target colour is changed from a 90 % reflectance Kodak white card to a 6 %, 13 % or 18 % reflectance surface.

Q50A Colour sensitivity

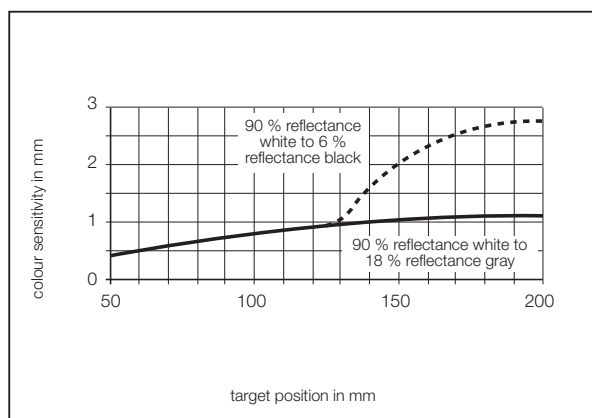

Q50B Colour sensitivity

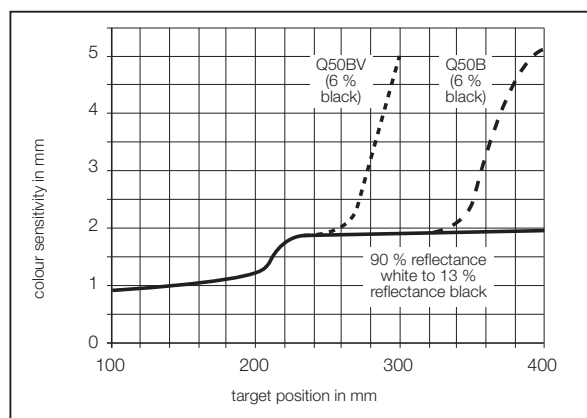

L-GAGE™ Q50 Series

with complementary discrete outputs

Sensing repeatability

Fast (Q50...Y)	1 % of sensing distance
Slow (Q50A, Q50B)	0,5 % of sensing distance

Minimum taught window (window limits versus taught distance – in mm)

	50	75	100	125	150	175	200	250	300	350	400
Q50A...	1	1,5	2	4	5	6	7	n/a	n/a	n/a	n/a
Q50AV...	1	1,5	2	4	5	n/a	n/a	n/a	n/a	n/a	n/a
Q50A...Y	2	3	4	7	9	12	15	n/a	n/a	n/a	n/a
Q50AV...Y	2	3	4	7	9	n/a	n/a	n/a	n/a	n/a	n/a
Q50B...	n/a	n/a	1	-	2	-	3,5	5	7	10	15
Q50BV...	n/a	n/a	1	-	2	-	3,5	5	7	n/a	n/a
Q50B...Y	n/a	n/a	2	-	4	-	7	10	14	20	30
Q50BV...Y	n/a	n/a	2	-	4	-	7	10	14	n/a	n/a

TEACH-Mode programming

Push-button procedure

- 1) Press the teach push-button until the teach LED turns red (hold button in for approx. 2 seconds). This indicates the sensor is waiting for the first window limit.
- 2) Position the target for the first limit. The range LED should be green, indicating a valid target. Briefly click the teach push-button. This will teach the sensor the first limit. The teach LED will flash red at 2 Hz to acknowledge receiving the first window limit; it is now waiting for the second limit.
- 3) Position the target for the second limit and click the teach push-button again to teach the sensor the second limit. The teach LED will return to either yellow or OFF as the sensor returns to RUN mode.
In case the first and the second limits are the same, the sensor will be set for single sensing set point.

Push buttons indications:

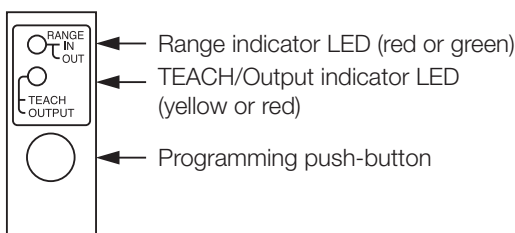

Programming a single pair of sensing window limits

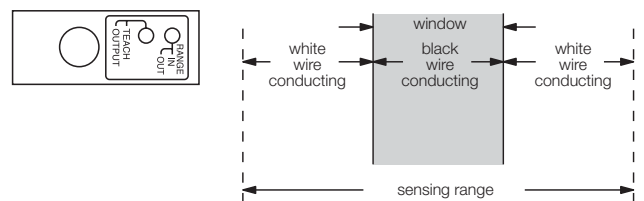

Programming separate sensing set points limits

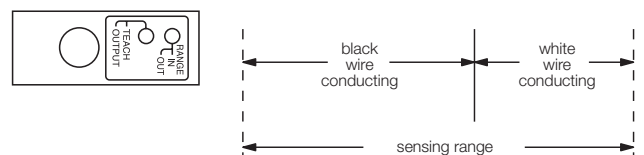

L-GAGE™ Q50 Series with complementary discrete outputs

Recommended sensor orientation for typical targets

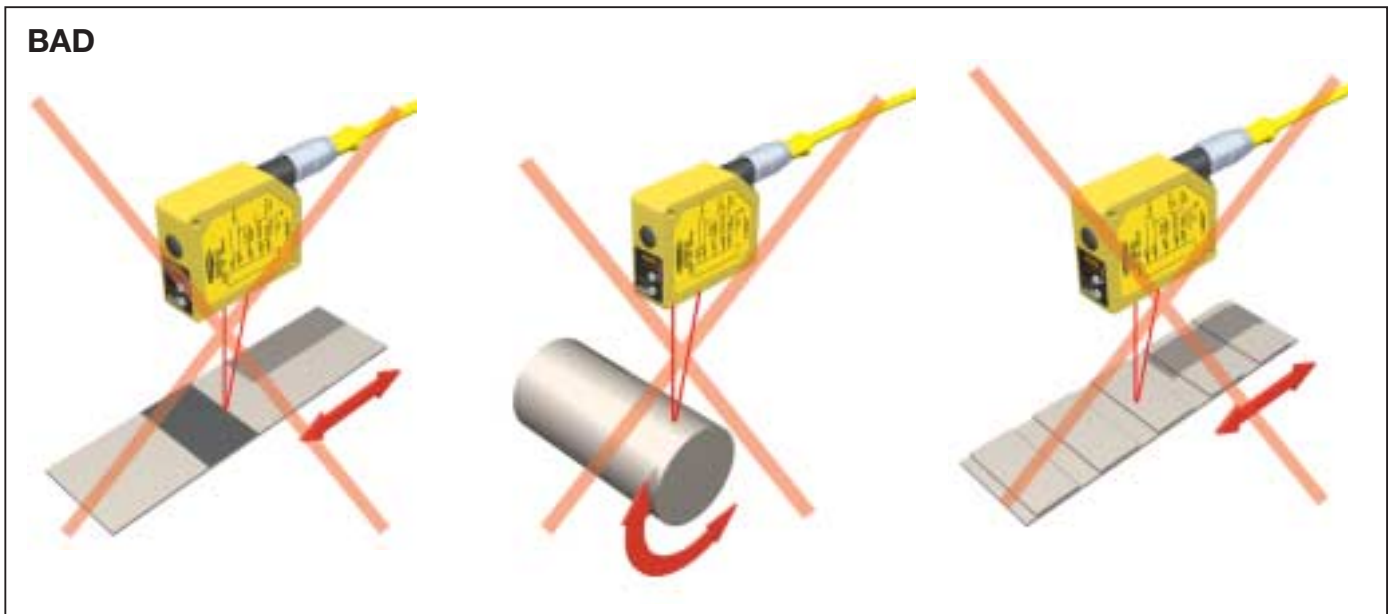

Application example

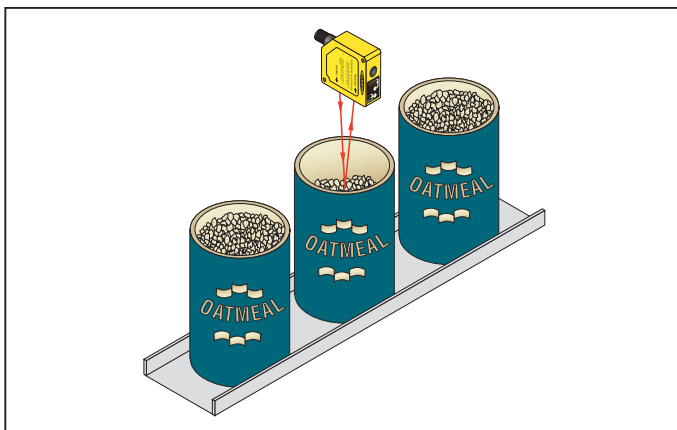

Fill level control

The purpose is to monitor and control fill level of dry cereal in a packaging operation. Many food processing lines now fill by level, instead of by weight. Q50 sensors are a very good choice for fill level monitoring of irregular surfaces, such as dry cereals.

Subject to changes without notice • Edition 02.02 • P/N ED075



IMPORTANT SAFETY WARNING! These sensors do NOT include the self-checking redundant circuitry necessary to allow their use in personnel safety applications. A sensor failure or malfunction can result in either an energised or de-energised output condition. These products should not be used as sensing devices for personnel safety.