

400 Series XPR™ Kit – Model 400-3/71



Contents

- 400 Series XPR™ Rotary Tool
- XPR™ Deluxe Storage Case
- XPR™ Planer
- Flex Shaft Attachment
- Circle Cutter
- 71 Assorted Accessories
- Quick Start Book
- Quick Change Collet Nut
- Wrench

Kit Accessories

150 Drill Bit	414 Small felt wheel (2)	432 Fine 1/2" sanding band (2)
401 Mandrel	420 HD Emery cut-off wheel (20)	438 Fine 1/4" sanding band (2)
402 Mandrel	421 Polishing Compound	540 1-1/4" Cut-off wheel bulk (2)
109 Engraving cutter	422 Felt Buff Cone	541 Aluminum oxide wheel
191 High speed cutter	425 Emery wheel (2)	561 Multipurpose Cutting Bit
403 Bristle brush	426 Fiberglass cut-off wheel	932 Aluminum oxide stone
404 Bristle brush	428 Carbon Steel Brush	953 Aluminum oxide stone
407 Coarse 1/2" sanding drum	429 Large felt wheel (2)	8193 Aluminum oxide stone
408 Coarse 1/2" sanding band (2)	430 Coarse 1/4" sanding drum	84922 Silicon carbide stone
411 Coarse sand discs (15)	431 Coarse 1/4" sanding band (2)	85602 Silicon carbide stone

400 Series XPR™ Kit – Model 400-6/90



Contents

- 400 Series XPR™ Rotary Tool
- XPR™ Deluxe Storage Case
- XPR™ MultiSaw
- XPR™ Planer
- Flex Shaft Attachment
- FlexLite™
- Cutting Guide
- Circle Cutter
- 90 Assorted Accessories
- Quick Start Book
- Quick Change Collet Nut
- Wrench

Kit Accessories

150 Drill Bit	414 Small felt wheel (5)	438 Fine 1/4" sanding band (3)
401 Mandrel	420 HD Emery cut-off wheel (20)	540 1-1/4" Cut-off wheel bulk (3)
402 Mandrel	421 Polishing Compound	541 Aluminum oxide wheel
109 Engraving cutter	422 Felt Buff Cone	561 Multipurpose Cutting Bit
191 High speed cutter	425 Emery wheel (4)	932 Aluminum oxide stone
194 High speed cutter	426 Fiberglass cut-off wheel (2)	952 Aluminum oxide stone
403 Bristle Brush	428 Carbon Steel Brush	953 Aluminum oxide stone
404 Bristle brush	429 Large felt wheel (2)	8193 Aluminum oxide stone
407 Coarse 1/2" sanding drum	430 Coarse 1/4" sanding drum	84922 Silicon carbide stone
408 Coarse 1/2" sanding band (3)	431 Coarse 1/4" sanding band (3)	85422 Silicon carbide stone
411 Coarse sand discs (20)	432 Fine 1/2" sanding band (3)	85602 Silicon carbide stone

Digital High Speed Rotary Tool – Model 398



Electronic feedback controller. Keeps speed constant under load at low and mid speed range.

Digital LCD readout. Provides accurate speed readouts in 1,000 RPM increments.

“Soft Start”. Allows the tool to come up to a selected speed gradually.

Separate on/off and variable speed buttons. Provides convenient speed adjustments and maintains selected speed, even when tool is switched off.



Variable speeds (5,000-35,000 RPM). Provides maximum control & precision.

Replaceable motor brushes. Longer tool life.

Ergonomic design. Balanced, easy to handle and comfortable to use.

Unique fan design. Maximizes airflow for cool motor performance.

Ball bearing construction. Smooth and quiet operation.



Digital High Speed Rotary Tool Kit – Model 3981-01

Kit Accessories

Contents

- Digital High Speed Rotary Tool
- Small Window Case
- Dremel Chuck
- 50 Assorted Accessories
- Quick Start Book
- Wrench

106 Engraving cutter	420 Heavy duty cut-off wheel (10)
150 Drill bit	425 Emery wheel
191 High speed cutter	426 Fiberglass cut-off wheel (2)
401 Mandrel	429 Felt wheel
402 Mandrel	430 Coarse 1/4" sanding drum
403 Bristle brush	431 Coarse sanding band (3)
407 Coarse 1/2" sanding drum	432 Fine sanding band (3)
408 Coarse sanding band (2)	438 Fine sanding band (2)
409 Emery cut-off wheels (2)	932 Aluminum oxide stone
411 Coarse sand discs (10)	8193 Aluminum oxide stone
414 Small felt wheels (2)	84922 Silicon carbide stone
415 Dressing stone	

ROUTER BITS For routing, inlaying, and mortising in wood and other soft materials. Use with Dremel No. 330 Router Attachment, No. 335 Plunge Router Attachment, and No. 231 Shaper/Router Table. Made of high speed steel.

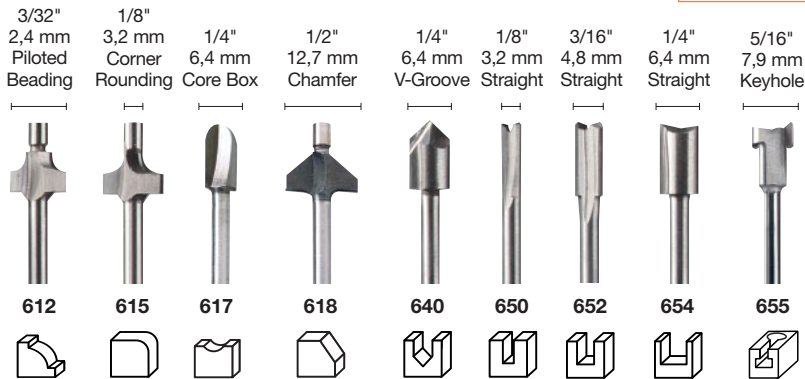
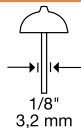

Grinding/Sharpening

SILICON CARBIDE GRINDING STONES (BLUE / GREEN)

Designed to work well on stone, glass, ceramics, porcelain and non-ferrous metals.

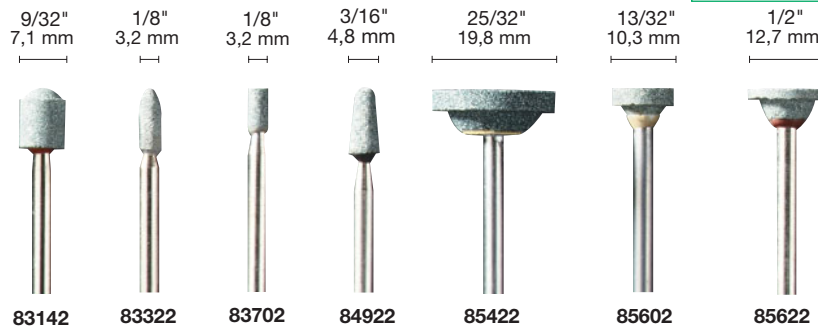
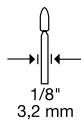

CHAIN SAW SHARPENING STONES Precision ground for quick, easy sharpening of chain saw blades. Each package contains 2 stones.

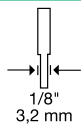
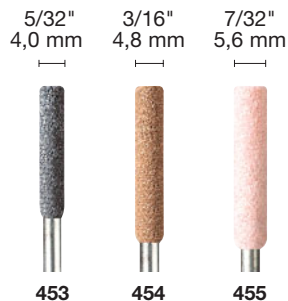

ALUMINUM OXIDE GRINDING STONES (ORANGE / BROWN)

Use on metals, castings, welded joints, rivets and rust. Ideal for sharpening, de-burring and general purpose grinding of most materials.

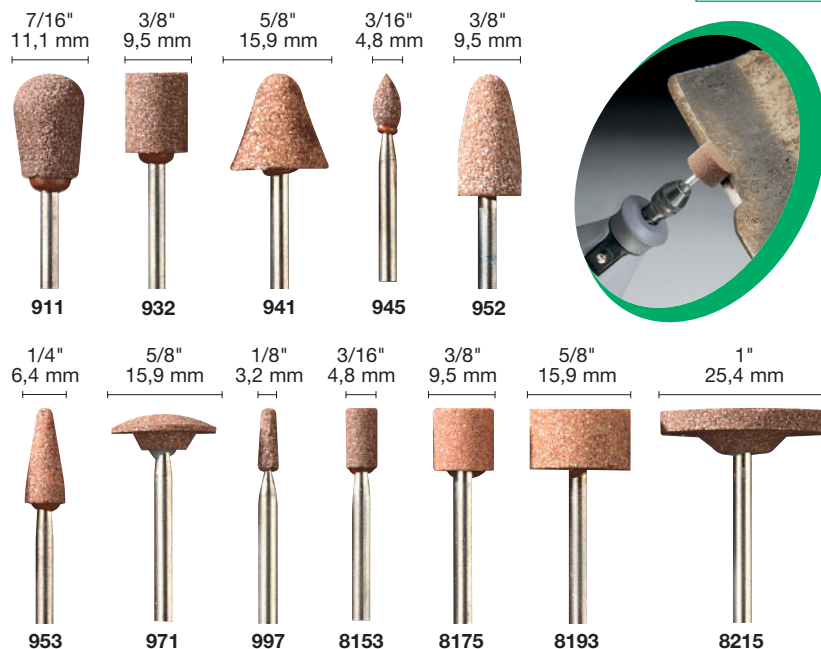
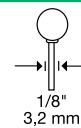

ALUMINUM OXIDE ABRASIVE WHEEL

Perfect for cleaning, de-burring, removing rust, and polishing of most metals, including stainless steel.

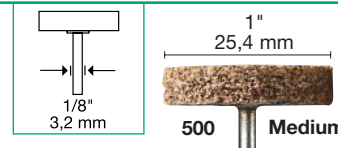

ALUMINUM OXIDE GRINDING WHEEL

Use for de-burring, rust removal and general purpose grinding.

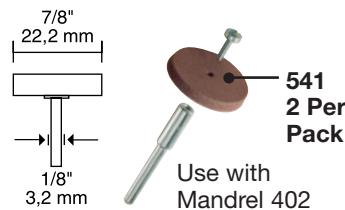

ABRASIVE POINTS

Abrasive points are great for finishing work and light de-burring. They can be used for paint and rust removal without removing any of the base material.





DREMEL®

**2005 Product and
Accessories Catalog**



For more information contact the Dremel Experts at:
1-800-437-3635 U.S.A. / 1-888-285-3476 CANADA
or online at: www.dremel.com