

# 1NT | SERIES

## FIXED TEMPERATURE THERMOSTATS

### Introduction

Single throw, snap-action, fixed temperature thermostat suitable for a variety of Industrial and commercial applications. 1NT is recognized by agencies around the world and depending on its configuration and application, is widely used as a regulating thermal switch, over-temperature control or pilot duty control switch.



### Features

- ISO9001: 2000 certification
- Ambient temperature rating from -40°C to 240°C (-40°F to 464°F)
- 1NT base provides:
  - Low cost
  - High temperature capability
  - Clean processing
  - High impact strength
  - Low static generation
- Many termination and mounting configurations available
- Switch actions:
  - Automatic reset: Available with both normally open and normally closed switch logic
  - Manual reset: Mechanical reset device
  - Trip free manual reset: UL M2 class rating that resists consumer tampering
  - One shot: meets agency requirements for single operation device

### Applications

- |   |   |
|---|---|
| <ul style="list-style-type: none"> <li>• Power Distribution</li> <li>• Automation</li> <li>• Power Supplies</li> <li>• Heating Systems</li> <li>• HVAC</li> <li>• Gas and Electric Furnace</li> <li>• Boilers</li> <li>• Espresso Machines</li> </ul> | <ul style="list-style-type: none"> <li>• Refrigeration</li> <li>• Electric motors</li> <li>• Heating Elements</li> <li>• Laboratory Equipment</li> <li>• Medical Equipment</li> <li>• Automotive &amp; HVOR</li> <li>• Panel Heaters</li> </ul> |
|---|---|



## STANDARD CONSTRUCTIONS

All dimensions mm (in.)

### High Profile Construction

Options shown: 90° – 1/4" Q.C. terminals with Surface mount flange

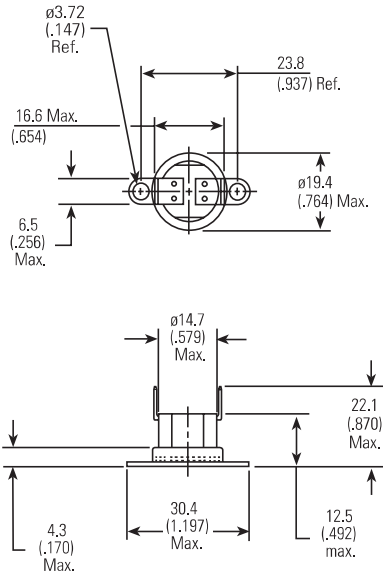

### Low Profile Construction

4 Post Options shown: 45° – 1/4" Q.C. terminals with 4 post and flat Al cup

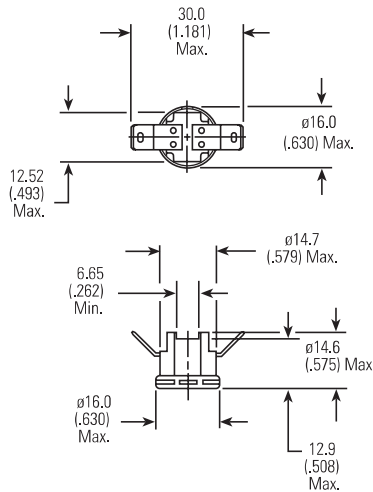

### Manual Reset Construction

Options shown: Flat 1/4" Q.C. terminals with Airstream mount cup

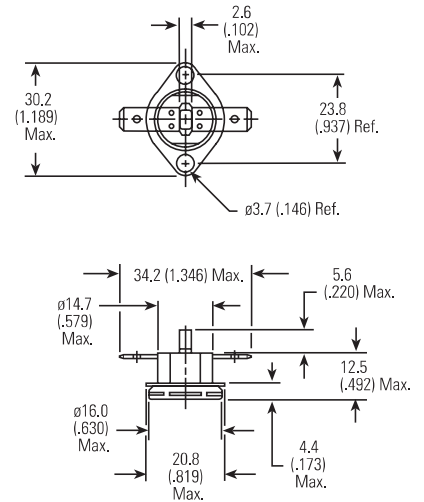

### Part Types by Construction

- 1NT01 Auto Reset / Silver Contacts
- 1NT11 Auto Reset / Gold Contacts
- 1NT09 One Shot: -35°C (-31°F) Reset
- 1NT10 One Shot: 0°C (32°F) Reset

- 1NT02 Auto Reset / Silver Contacts
- 1NT02TL Low Profile / One Shot
- 1NT20 Auto Reset / Gold Contacts

- 1NT08 Manual Reset / Silver Contacts
- 1NT12 Manual Reset / Gold Contacts
- 1NT15 Trip Free MR / Silver Contacts
- 1NT19 Trip Free MR / Gold Contacts



## STANDARD TEMPERATURES, TOLERANCES AND DIFFERENTIAL

### Manual Reset and One-Shot Thermostats

Nominal Top Temperature		Open Tolerances	
°C	°F	°C	°F
<60	<140	±4.0	±7.5
61 TO 160	141 to 320	±5.0	±9.0
161 TO 204	321 to 399	±6.0	±11.0

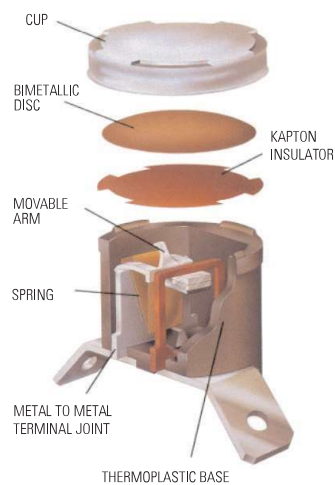

# Automatic Reset Thermostats

Nominal Top Temperature		Min. Bottom Temperature		Differential		Standard Tolerances			
						Open		Close	
°C	°F	°C	°F	°C	°F	°C	°F	°C	°F
18 to 27	65 to 80	-33	-26	11 to 16 17 to 21 22 to 33	20 to 29 30 to 38 39 to 59	±3.0 ±3.0 ±3.0	±5.5 ±5.5 ±5.5	±4.0 ±4.5 ±5.5	±7.5 ±8.5 ±10.0
28 to 80 and 81 to 93 <sup>(1)</sup>	81 to 176 and 177 to 199	-33 50	-26 122	11 to 13 14 to 16 17 to 33	20 to 23 24 to 29 30 to 59	±3.0 ±3.0 ±3.0	±5.5 ±5.5 ±5.5	±4.0 ±4.5 ±5.0	±7.5 ±8.5 ±9.0
94 to 121 <sup>(1)</sup>	200 to 249 <sup>(1)</sup>	50	122	11 to 16 17 to 21 22 to 33 34 to 55	20 to 29 30 to 38 39 to 59 60 to 99	±3.5 ±3.5 ±3.5 ±5.5	±6.5 ±6.5 ±6.5 ±10.0	±4.5 ±5.5 ±6.5 ±11.0	±8.5 ±10.0 ±12.0 ±20.0
122 to 149	250 to 300	50	122	14 to 21 21 to 33 34 to 55	24 to 38 39 to 59 60 to 99	±4.0 ±4.0 ±5.5	±7.5 ±7.5 ±10.0	±5.5 ±8.0 ±11.0	±10.0 ±14.5 ±20.0
150 to 177	301 to 350	50	122	22 to 33 34 to 44 45 to 55	39 to 59 60 to 79 80 to 99	±5.0 ±5.5 ±5.5	±9.0 ±10.0 ±10.0	±9.0 ±11.0 ±11.0	±16.5 ±20.0 ±20.0
178-204 <sup>(2)</sup>	351 to 399	50	122	22 to 33* 34 to 44 45 to 55	39 to 59 60 to 79 80 to 99	±5.0 ±5.5 ±5.5	±9.0 ±10.0 ±10.0	±9.0 ±11.0 ±11.0	±16.5 ±20.0 ±20.0

<sup>(1)</sup> Not valid for Fan Devices

<sup>(2)</sup> Top Temp for Fan Devices cannot exceed 380°F (193°C)

## ACCESSORIES AND OPTIONS

### Flanges

#### Fixed Rotation Surface Mount Flange 57336

Available mounting rotation relative to terminals - 90° with Aluminum  
-0°, 90° / or 57°, 127°, 135° CCW with Nickel Plated Steel

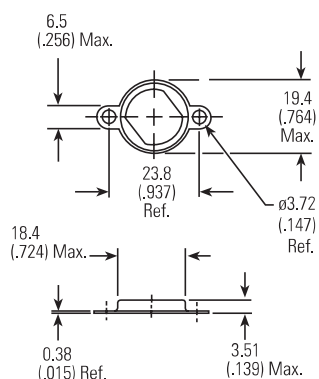

#### Loose Ear Surface Mount Flange 27183

Material: Aluminum

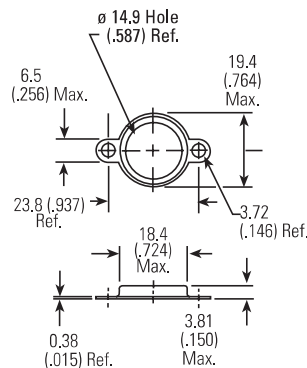

#### Wide Eared – Fixed Rotation Mounting Flange 57337

Material: Nickel Plated Steel  
Available mounting rotation relative to terminals - 45° CCW

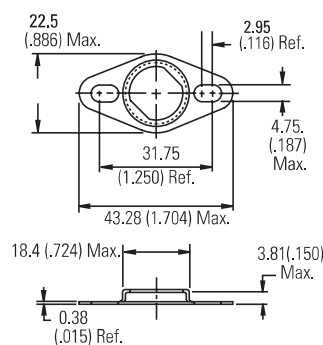

#### Bolt On Assembly 73972

Thread Specs:	Metric:	M4 x 0.7 - 6G M5 x 0.8 - 6G
	Stud Length:	Metric: 6.15, 7.00, 8.00, 9.00 (with M4) 8.00 (with M5) English: 6 x 32 - 1/2" Long 8 x 32 - 1/4" Long
Material:	Stud:	Zinc Plated Steel
	Cap:	Aluminum

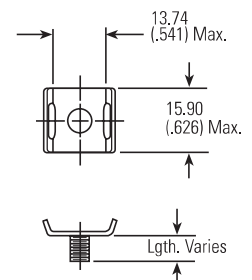

# Cup Styles

## Airstream Mount Integral Cup 57611

Material: Aluminum  
Available mounting rotation relative to terminals – 0° or 90° Closed Bottom Only

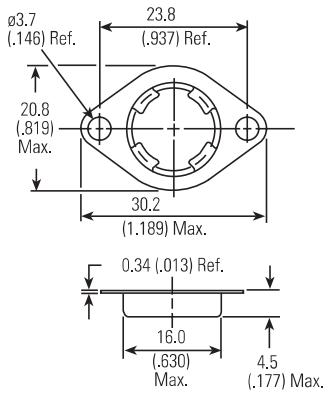

## Flat Cup 73926

Materials: Aluminum, Stainless Steel or Copper

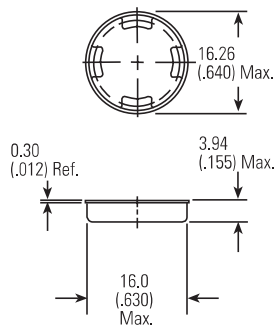

## 3NT Flange Cup 57366

Material: Aluminum or Copper  
Closed Bottom Only

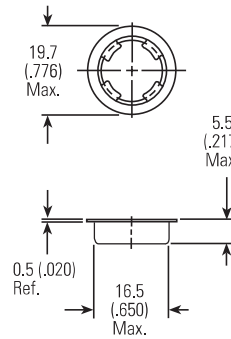

## Airstream Mount Integral Cup 27185

Material: Stainless Steel  
Available mounting rotation relative to terminals  
0°, 45° or 90° with Closed Bottom  
0° or 90° with Open Bottom

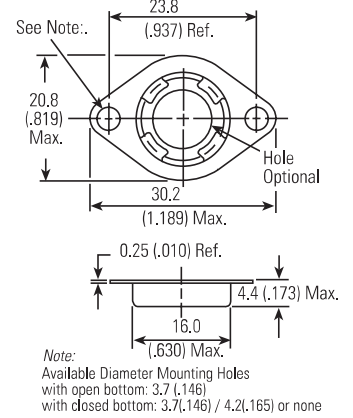

## Airstream Mount Integral Cup (slotted mounting holes) 57367

Material: Aluminum  
Available mounting rotation relative to terminals - 0° or 90° Closed Bottom Only

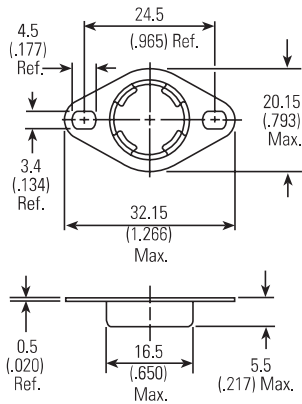

## Wide-Eared Integral Cup 57608

Material: Stainless Steel  
Available mounting rotation relative to terminals - 0° or 90° Closed Bottom Only

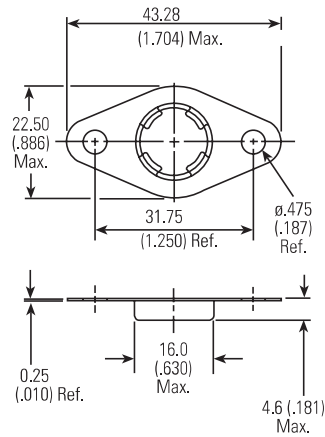

## “Tear-Drop” Integral Cup 57609

Material: Stainless Steel  
Available mounting rotation relative to terminals - 0° or 90° Closed Bottom Only

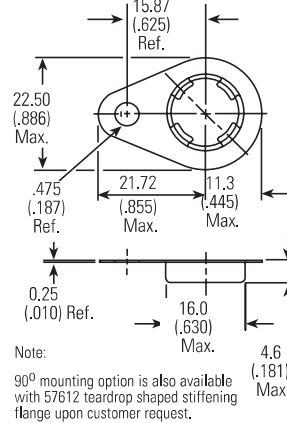

## Large Oval Integral Cup 59122

Material: Aluminum  
Available mounting rotation relative to terminals  
0°, 45° or 90° with Closed Bottom  
0° or 90° with Open Bottom

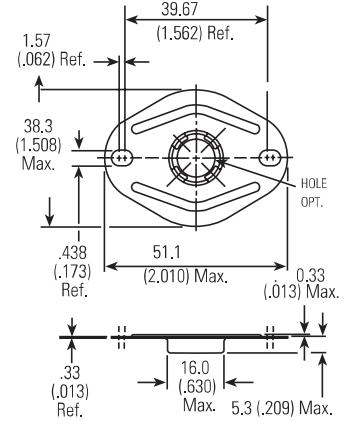

# Standard Terminal

## Solder Terminal 27182\*

Material: Tin Plated Brass

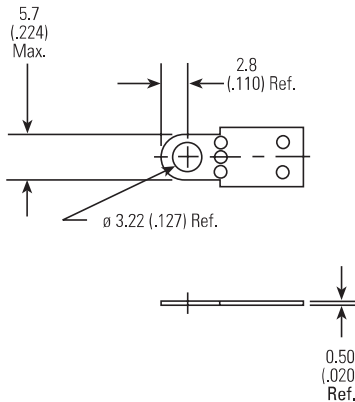

## Crimp Terminal 27184\*

Material: Tin Plated Brass

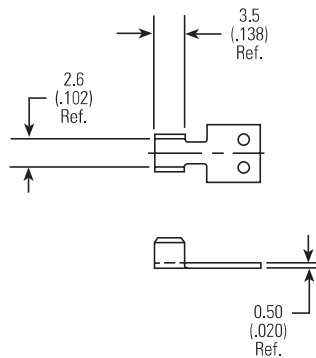

## Quick Connects

**27132 27162\* 27163**  
 Thickness (A): 0.8(.031) 0.5(.020) 0.8(.031)  
 Width (B): 6.3(.250) 4.8(.187) 4.8(.187)  
 Materials: Brass - Solid, Ni, Ag, or Tin Plated  
 Steel - Nickel Plated

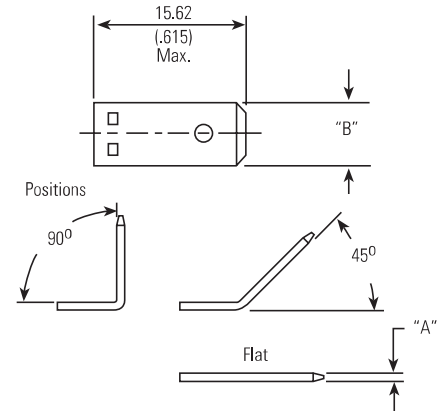

## Screw Terminal 57200

Material: Nickel Plated Steel  
 M3 x 0.5 Class 6H Thread

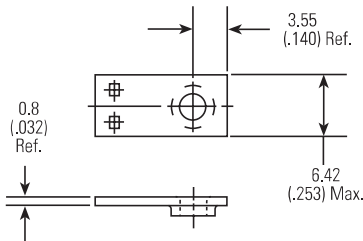

## Weld Terminal 57201

Material: Nickel Plated Steel

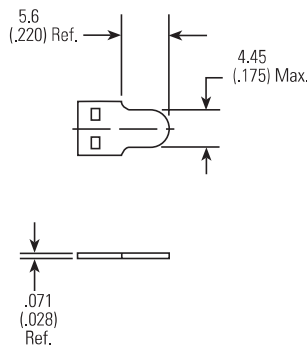

## Weld Terminal 57312\*

Material: Nickel Plated Steel

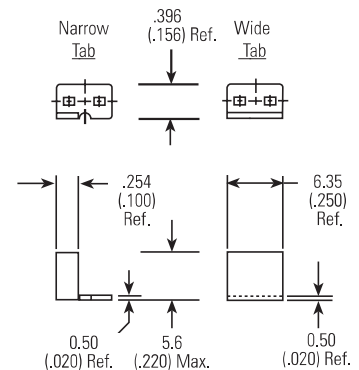

\*10A Max. on all terminals 0.51 (.020) thick  
 All dimensions mm (in.)

## ORDERING OPTIONS

**EXAMPLE**      1NTXX    E    L    XXXX

<b>Family</b>	1NTXX	E	L	XXXX
See Standard Construction Table				
<b>Special Processing</b>		E		
A - Wire Lead Assy				
E - Exposed Disc				
<b>Switch Type</b>			L	
L - Limit <sup>(3)</sup> switch opens on temperature rise				
F - Fan <sup>(4)</sup> switch closes on temperature rise				
<b>ID Number</b>				XXXX
Unique Number Designated by the factory to indicate all other attributes including Temperatures, Terminals or connectors, Mounting Options, Special Markings, and other special customer requested requirements.				

<sup>(3)</sup> Limit switch opens on temperature rise

<sup>(4)</sup> Fan switch closes on temperature rise

The Temperature Code is required to set up or choose the unique part number for your application requirements.

## Temperature Code

**EXAMPLE**      L    150    F    30

<b>Operating Temperature</b>	L	150	F	30
L - Limit				
F - Fan				
<b>Operating Temperature</b>		150		
Nominal Open				
Temperature				
<b>Temp. Code</b>			F	
C - Celsius				
F - Fahrenheit				
<b>Differential</b>				30
## Nom. Open to Nom. Close				
MR Manual Reset				



UL and C-UL

Type	Max. Temp.		Cycles (X 1000)	Electrical Rating	
	°C	°F			
1NT01, 02	204	400	100	120 Vac	0 - 9 amps 10 - 17 amps*
				240 Vac	0 - 5 amps 6 - 17 amps*
				277 Vac	7.2 amps
1NT08, 15, 08E**	204	400	1 + 5	240 Vac	25 amps
1NT09, 10	204	400	1-Shot	240 Vac 277 Vac	25 amps 7.2 amps
1NT11, 20	204	400	100	125 VA 30 Vdc	1 amp
1NT12, 19	204	400	1 + 5	125 VA	
1NT01E, 02E**	204	400	100	120 Vac	10 amps

\* UL rated at these current levels at specific open/close temperatures. When applying to these electrical levels, nominal open/close temperatures must be considered to determine if the thermostat selected will operate as intended in the user's application. Please consult a Sensata Engineer for additional clarification.

\*\* "E" means exposed disc.

ENEC (DEKRA)

Type	Max Temp (°C)	Cycles	Electrical Rating
1NT01/02	204	100.000	240Vac 13.5(1.66)A
		30.000	240Vac 16(5)A
		30.000	400Vac 4(1)A
1NT02T	204	1	240Vac 16(5)A
1NT08	204	10.000	240Vac 16(5)A
		10.000	400Vac 4(1)A
1NT09	204	1	240Vac 16(5)A
1NT11	204	100.000	30Vdc 1A
1NT12	204	10.000	30Vdc 1A
1NT15	204	10.000	240Vac 16(5)A
1NT20	204	100.000	30Vdc 1A
1NT30	204	10.000	30Vdc 1A
1NT31	204	10.000	30Vdc 1A

\* Parenthesis indicate inductive load ratings.

\*\* ENEC rated at these current levels at specific open/close temperatures. When applying to these electrical levels, nominal open/close temperatures must be considered to determine if the thermostat selected will operate as intended in the user's application. Please consult a Sensata Engineer for additional clarification.



THERMOSTAT HANDLING TIPS

1. Exposed disc devices should be kept free of dust and particulates, liquid and condensation. The face of the disc should never be snapped.
2. Mounting screws and drivers for use with smaller integral cups and flanges should be sized to provide adequate clearance to the thermostat body.
3. The installation force applied to the cup face should not exceed 66.7N (15 lbs.).
4. The maximum reset force on the manual reset and trip free button is 22.2N (5 lbs.).

IMPORTANT NOTICE

**These devices are not intended for use as service or repair components, strictly for use by Original Equipment Manufacturer. This product is not rated as explosion proof and should not be applied in any application where flammable vapors or dust is present. End of life failure of this device may result in either open or closed circuit condition, and as such, OEMs must apply end of life protection in series, per agency requirements.**

**Users are solely responsible for proper design, application and function of this product in the end product or system. Users must evaluate the suitability of these devices in their application with respect to Temperature Settings, Mechanical and Electrical Life Cycles, Electrical loads and Environmental conditions.**

**These products are not environmentally sealed and have exposed electrical components. They are not intended to be used in applications where exposure to condensing or dripping liquids, Immersion in liquids, or exposure to other environment contaminants may occur.**

**Excessive mechanical cycling, high electrical loading or exposure to liquids or other environmental contaminants, as noted above, may compromise the electrical insulating properties of these devices. Such conditions may result in electric insulation breakdown accompanied by localized heating. The device may remain permanently closed or open as a result of these conditions as well as at normal end of life.**



## WARNINGS



### RISK OF MATERIAL DAMAGE AND HOT ENCLOSURE

- The product's side panels may be hot, allow the product to cool before touching
- Follow proper mounting instructions including torque values
- Do not allow liquids or foreign objects to enter this product

**Failure to follow these instructions can result in serious injury, or equipment damage.**



### HAZARD OF ELECTRIC SHOCK, EXPLOSION OR ARCH FLASH

- Disconnect all power before installing or working with this equipment
- Verify all connections and replace all covers before turning on power

**Failure to follow these instructions will result in death or serious injury**

Sensata Technologies, Inc. ("Sensata") data sheets are solely intended to assist designers ("Buyers") who are developing systems that incorporate Sensata products (also referred to herein as "components"). Buyer understands and agrees that Buyer remains responsible for using its independent analysis, evaluation and judgment in designing Buyer's systems and products. Sensata data sheets have been created using standard laboratory conditions and engineering practices. Sensata has not conducted any testing other than that specifically described in the published documentation for a particular data sheet. Sensata may make corrections, enhancements, improvements and other changes to its data sheets or components without notice.

Buyers are authorized to use Sensata data sheets with the Sensata component(s) identified in each particular data sheet. HOWEVER, NO OTHER LICENSE, EXPRESS OR IMPLIED, BY ESTOPPEL OR OTHERWISE TO ANY OTHER SENSATA INTELLECTUAL PROPERTY RIGHT, AND NO LICENSE TO ANY THIRD PARTY TECHNOLOGY OR INTELLECTUAL PROPERTY RIGHT, IS GRANTED HEREIN. SENSATA DATA SHEETS ARE PROVIDED "AS IS". SENSATA MAKES NO WARRANTIES OR REPRESENTATIONS WITH REGARD TO THE DATA SHEETS OR USE OF THE DATA SHEETS, EXPRESS, IMPLIED OR STATUTORY, INCLUDING ACCURACY OR COMPLETENESS. SENSATA DISCLAIMS ANY WARRANTY OF TITLE AND ANY IMPLIED WARRANTIES OF MERCHANTABILITY, FITNESS FOR A PARTICULAR PURPOSE, QUIET ENJOYMENT, QUIET POSSESSION, AND NON-INFRINGEMENT OF ANY THIRD PARTY INTELLECTUAL PROPERTY RIGHTS WITH REGARD TO SENSATA DATA SHEETS OR USE THEREOF.

All products are sold subject to Sensata's terms and conditions of sale supplied at [www.sensata.com](http://www.sensata.com) SENSATA ASSUMES NO LIABILITY FOR APPLICATIONS ASSISTANCE OR THE DESIGN OF BUYERS' PRODUCTS. BUYER ACKNOWLEDGES AND AGREES THAT IT IS SOLELY RESPONSIBLE FOR COMPLIANCE WITH ALL LEGAL, REGULATORY AND SAFETY-RELATED REQUIREMENTS CONCERNING ITS PRODUCTS, AND ANY USE OF SENSATA COMPONENTS IN ITS APPLICATIONS, NOTWITHSTANDING ANY APPLICATIONS-RELATED INFORMATION OR SUPPORT THAT MAY BE PROVIDED BY SENSATA.

Mailing Address: Sensata Technologies, Inc., 529 Pleasant Street, Attleboro, MA 02703, USA.

## CONTACT US

### Americas

+1 (888) 438 2214  
sensors@sensata.com

### Europe, Middle East & Africa

+31 (74) 357 8156  
temperature-info.eu@sensata.com

### Asia Pacific

sales.isasia@list.sensata.com  
China +86 (21) 2306 1500  
Japan +81 (45) 277 7117  
Korea +82-10-9218-1179  
India +91 (80) 67920890  
Rest of Asia +886 (2) 27602006  
ext 2808