

SH. 1  
OF 1

CAT NO

117A

CUSTOMER DIMENSIONS

DO NOT  
SEPARATE  
PRINT FROM  
WORK

LOT NO

OPER

TOOLS

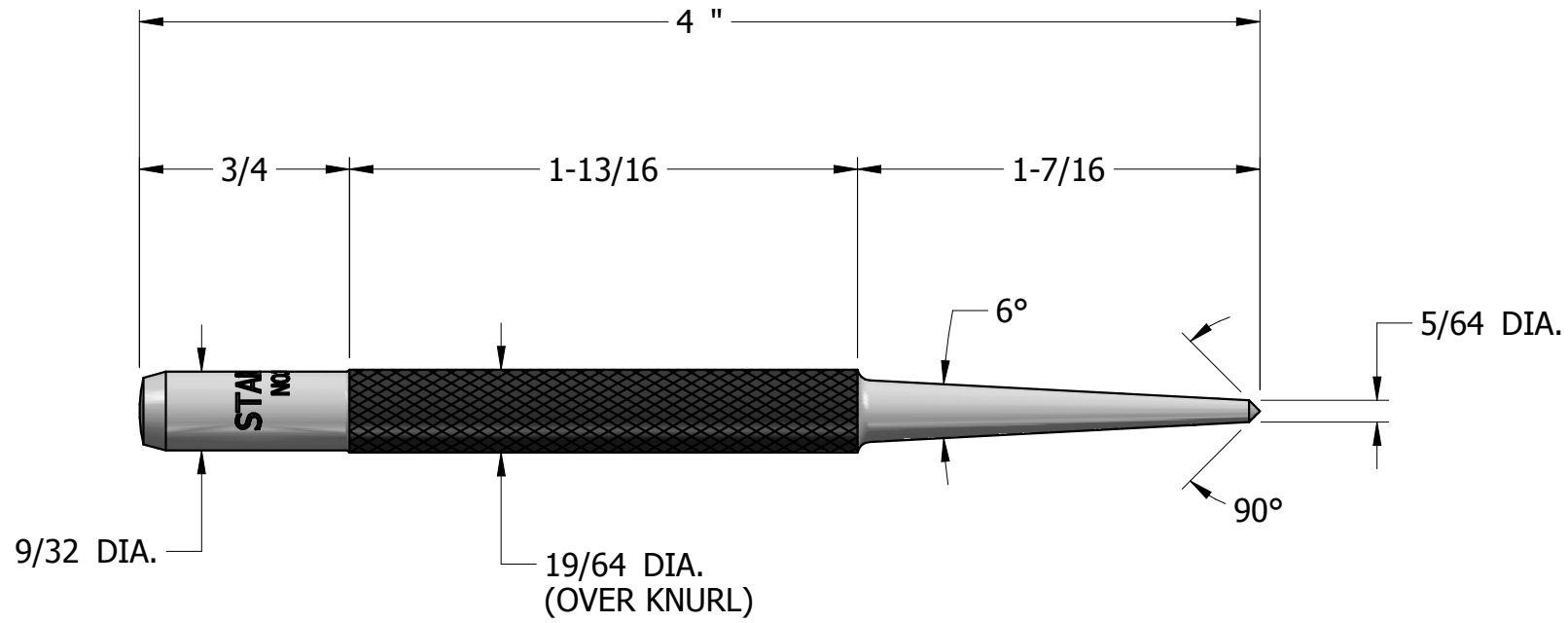

REV	DESCRIPTION	DATE	BY
DR	CHK	DATE	

5/64 CENTER PUNCH

TOLERANCES - UNLESS OTHERWISE SPECIFIED

1 PLACE DEC. or REF. : +/- .015" --- 0.4 mm  
2 PLACE DEC. : +/- .010" --- 0.25 mm

3 PLACE DEC. : +/- .003" --- 0.08 mm  
4 PLACE DEC. : +/- .0005" --- 0.01 mm

FRACTIONAL: +/- 1/64"  
ANGULAR: +/- 1 DEGREE

THE L.S. STARRETT CO.  
ATHOL, MASS.