

FACTORY AUTOMATION – SENSING YOUR NEEDS

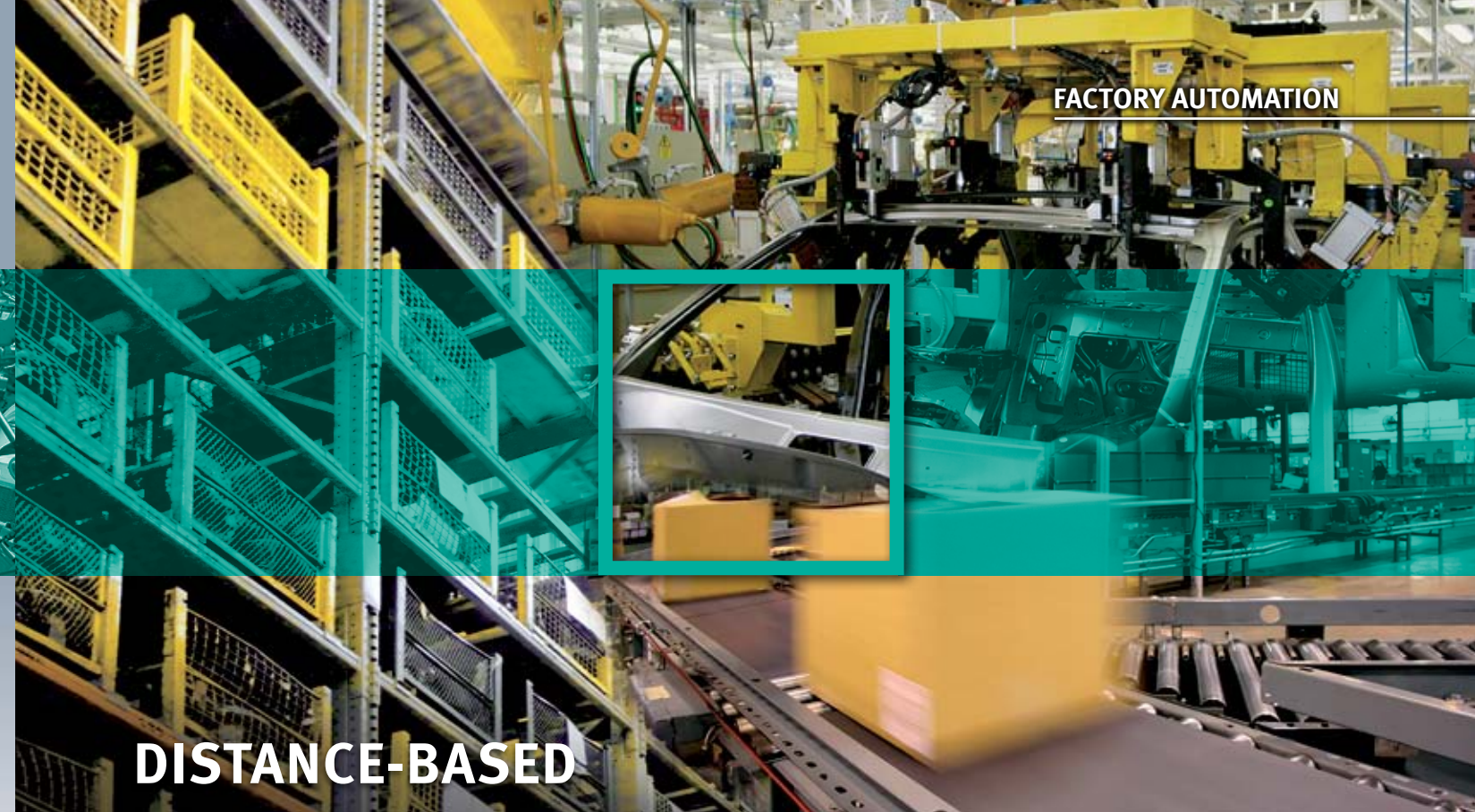

Background Suppression (BGS) sensors easily and precisely sense objects up to a defined distance but not beyond. Light from the sensor's emitter is reflected by an object to the sensor's two-segment receiver at varying angles depending on the object's distance. Depending on that triangulation angle—and subsequently which receiver segment sees more reflected light—the object is either detected or suppressed.

Not only are background machine panels, conveyors, and sidewalls correctly ignored, but materials and products with varying colors and printing are seen at a consistent distance with no adjustment needed.

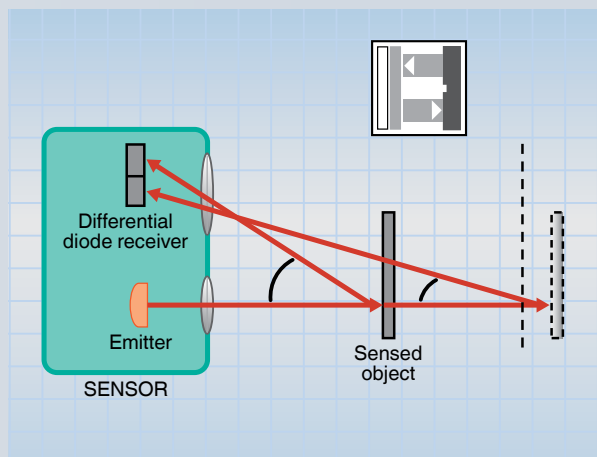

Multi-pixel Array (MPA) sensors detect objects either up to a defined distance or within a defined span. Like BGS sensors, light from the sensor's emitter is reflected by an object to the sensor's receiver at varying angles depending on distance. But an MPA receiver is an array of more than two—possibly over one hundred—segments. The triangulation angle—and subsequently where reflected light contacts the array—determines if the object is detected.

Its unique receiver enables a greater range of sensing modes and configurations so sensing can be customized to a specific application.

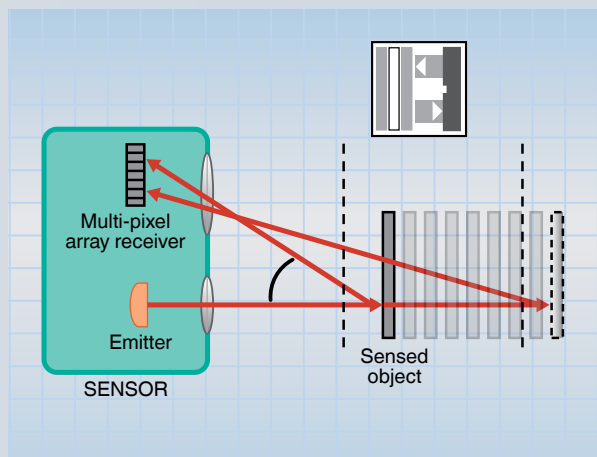

Pulse Ranging Technology (PRT) devices accurately measure the distance to an object or reflector. The sensor's emitter sends short, intense bursts of light that are reflected back to the sensor's single receiver. Using the speed of light as a constant, the sensor calculates the duration between the time the pulse was sent and the time it was received and then determines the distance to the object.

Offering continuous distance data, it measures the actual distance to an object or reflector with repeatability and precision.

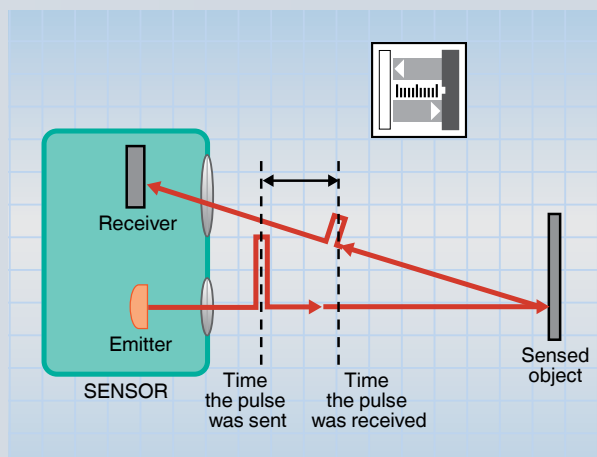

Pepperl+Fuchs sets the standard in quality and innovative technology for the world of automation. Our expertise, dedication, and heritage of innovation have driven us to develop the largest and most versatile line of industrial sensor technologies and interface components in the world. With our global presence, reliable service, and flexible production facilities, Pepperl+Fuchs delivers complete solutions for your automation requirements—wherever you need us.



DISTANCE-BASED PHOTOELECTRIC SENSING



DISTANCE-BASED PHOTOELECTRIC SENSING

Photoelectric sensors that only detect the absence or presence of an object may not suffice for every application. Distance-based photoelectric sensors address more challenging application requirements by not only determining the presence of something, but also its position. Three methods have emerged as front-runners of distance-based photoelectric sensing.



BACKGROUND SUPPRESSION (BGS) SENSORS

| | |
|-------------------------------|---|
| How Does It Work? | Triangulates reflected light to differential diode |
| What Does It Indicate? | If an object is closer than a defined distance |
| Why Use It? | To sense object while ignoring background or color variation |
| Applications | Detecting varying products, presence check in tight space, leading edge detection |
| Advantages | Simplicity; tight switching hysteresis, product breadth; economical |



BACKGROUND SUPPRESSION (BGS) SENSORS



Typical BGS Applications:

- Detect cookies in a plastic tray
- Verify hole presence in a mold assembly
- Trigger barcode reads
- Sense filters in a nozzle head
- Monitor stack height

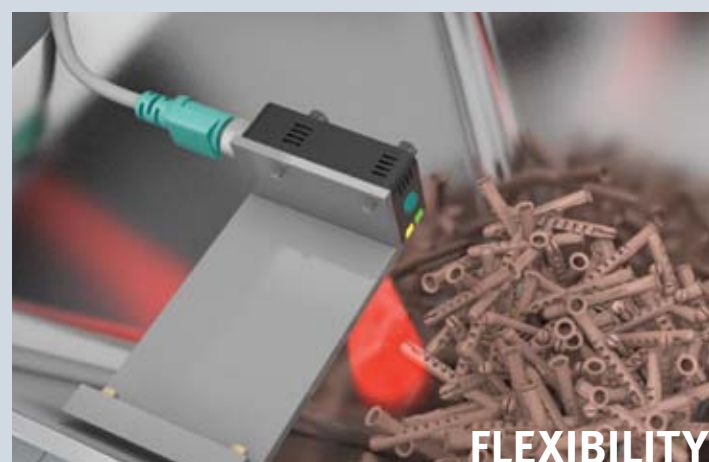

MULTI-PIXEL ARRAY (MPA) SENSORS

| | |
|-------------------------------|--|
| How Does It Work? | Triangulates reflected light to array |
| What Does It Indicate? | If an object is closer than a defined distance or in a defined window |
| Why Use It? | To customize sensing thresholds or ranges |
| Applications | Presence check, tension monitoring; leading edge detection, web break monitoring, stroke height monitoring |
| Advantages | Balances flexibility and simplicity; multiple modes; economical |



MULTI-PIXEL ARRAY (MPA) SENSORS



Typical MPA Applications:

- Web tension monitoring
- Leading edge monitoring of reflective and irregularly contoured objects
- Fill level monitoring
- Web break detection
- Dancer arm stroke height control

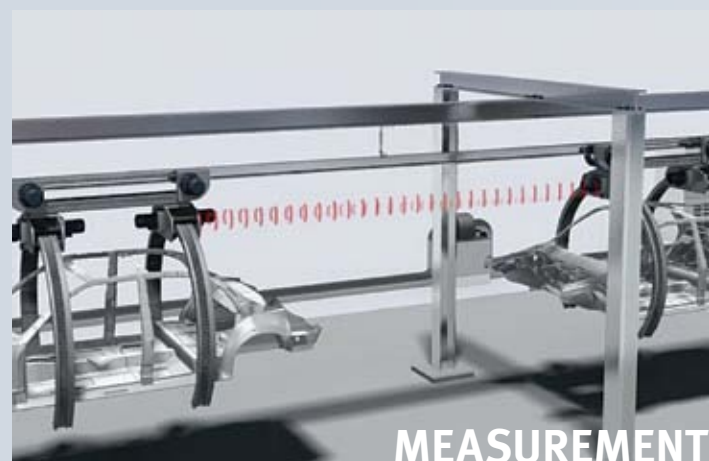
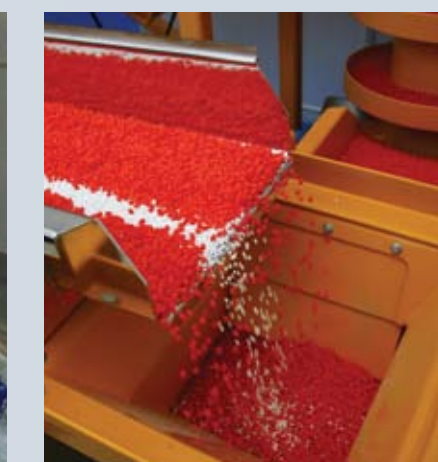
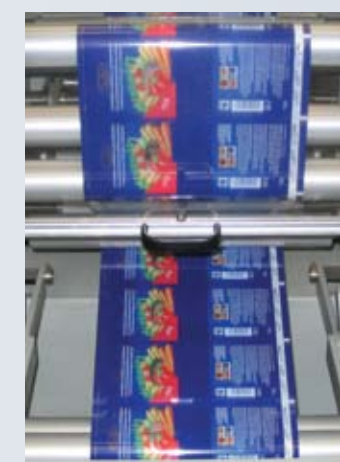

PULSE RANGING TECHNOLOGY (PRT) SENSORS

| | |
|-------------------------------|--|
| How Does It Work? | True time-of-flight calculation using reflected light pulses |
| What Does It Indicate? | Distance to an object |
| Why Use It? | To measure distance |
| Applications | Monitoring proximity, determining position, measuring dimensions |
| Advantages | Distance output, flexibility |

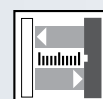

PULSE RANGING TECHNOLOGY (PRT) SENSORS



Typical PRT Applications:

- Collision avoidance on overhead conveyors
- Measurement of distance to stacker crane
- Container dimensions measurement
- Elevator positioning
- Precise level measurement

