

Mastering challenges.
Opening communication channels.
Redefining flexibility.

R10x and R20x Series
Standard Housings—All Sensing Modes



Forward-Thinking Product Design— Endless Application Possibilities

A complete family of sensing modes in five standard housing styles with one user interface and IO-Link in every model. The forward-thinking design of Pepperl+Fuchs' R100, R101, R103, R200, and R201 series simplifies installation and reduces costs.



Versatility Meets Simplicity

These innovative sensor families combine all photoelectric sensing modes in five standard housing styles. The R100, R101, and R103 series are ideal for short-range applications, and the new R200 and R201 series are perfect for longer-range sensing. Together, they provide unparalleled flexibility, regardless of the application or installation requirements.

One user interface across all families ensures efficiency. And a standardized IO-Link interface with Smart Sensor Profile offers a future-proof solution.



Highlights

- All photoelectric sensing modes in standard housing styles for maximum flexibility and more integration possibilities
- Simple installation and setup with one user interface for all housing styles and sensing modes
- IO-Link and Smart Sensor Profile in every sensor: standardized communication down to the sensor level as the basis for Sensorik4.0®
- Precise and reliable MPT distance measurement in a standard small housing
- Innovative DuraBeam laser technology for an exceptionally long life and increased operating temperature range

Five Housing Styles, One User Interface

All R10x and R20x sensors in all sensing modes have the same user interface. The intelligent combination of a multiturn potentiometer and pushbutton control enables intuitive adjustment of all functions and simplifies setup.

Easy and Intuitive Configuration

The R10x and R20x series are designed to minimize complexity. Retroreflective, diffuse, and measuring sensors alike have the same simple user interface and are configured the same way. In addition to the user interface, IO-Link can also be used for configuration. IO-Link and Smart Sensor Profiles increase efficiency and reduce the complexity of sensor integration.

Installation without Limitation

Each R10x and R20x sensor offers several mounting patterns in one industry-standard housing style. Compatibility with a variety of common solutions on the market gives users the freedom to adapt to virtually any installation requirement. New R20x sensors for longer-range sensing also feature rotatable connectors, which allows flexible installation, even in space-restricted applications.



Sensorik4.0[®]: Future-Proof Automation with IO-Link

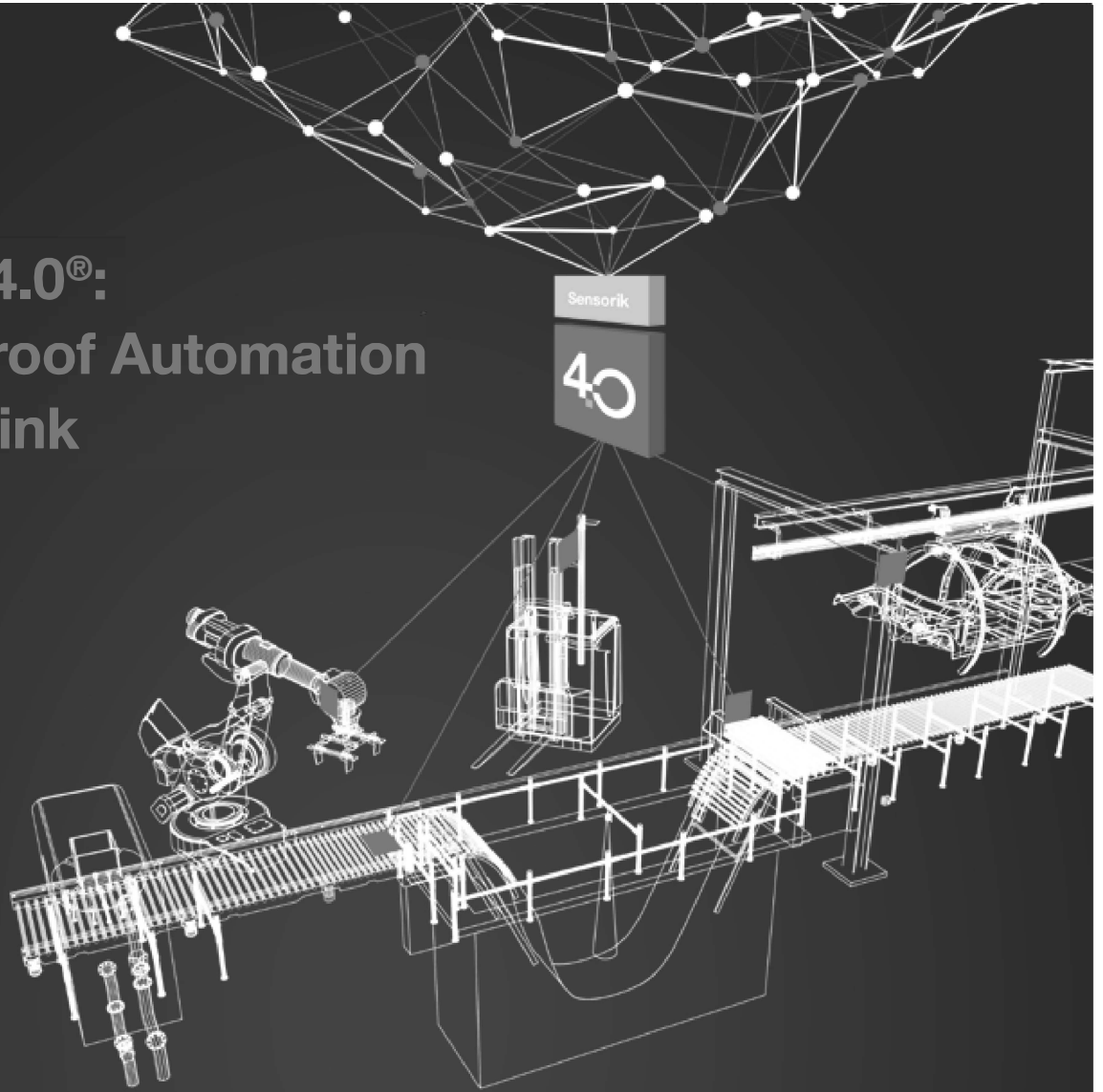

Industry 4.0: New Challenges for Automation

To manage the tasks of the future, sensors need to do more than simply deliver process data to the machine controller. They must be able to communicate with all different kinds of receivers, and send and receive sensor data to and from higher-level information systems. The key to achieving this is the ability of the sensors themselves to communicate. This is the defining characteristic of Sensorik4.0[®]—the sensor technology of the future that Pepperl+Fuchs is developing to meet the requirements of digital networking in Industry 4.0.

State-of-the-art IO-Link technology serves as an interface that allows us to unlock the sensors' ability to communicate.

Smart Sensor Profile: Pioneering the Standardization of IO-Link

Smart Sensor Profile is a standard that aims to ensure the same basic functionalities across all IO-Link sensor manufacturers. This includes access to settings, parameters, process data, and diagnostics.

All sensors that follow a specific Smart Sensor Profile display and evaluate process data the same way. This enables the use of function blocks for simple control integration. Existing user programs can be reused, which simplifies programming.

Pepperl+Fuchs is among the first manufacturers to implement version 2 of Smart Sensor Profile, the latest version published by the IO-Link consortium. This standard will also be implemented in future Pepperl+Fuchs products.



Unique Technologies, Absolute Reliability

Two unique technologies differentiate R10x and R20x sensors: DuraBeam laser technology and Multi Pixel Technology (MPT). Increased precision, power, and reliability are some of the benefits made possible by these innovative technologies.

DuraBeam: Higher-Performance Laser Technology

Eye-safe DuraBeam laser technology from Pepperl+Fuchs combines the advantages of an LED emitter—long service life and extended temperature range—with the strengths of laser diodes—long detection and sensing ranges as well as a more intense beam quality. As a result, R10x and R20x laser sensors are more energy-efficient and last longer without compromising performance, even in extreme operating temperatures. Another benefit of DuraBeam laser sensors is their special beam profile, which casts a sharp, circular light spot on an object. This makes them ideal for extremely precise detection and distance measurement of small objects.



Long life



Sharp light spot



Higher temperature range



MPT: State-of-the-Art Distance Measurement

Pepperl+Fuchs' Multi Pixel Technology uses the advantages of geometric triangulation for distance measurement, enabling highly precise, reliable measurement even at close range. The sensor's light source creates an extremely bright, high-energy light spot on the object and thus a reflection that is precisely reproduced on the receiving multipixel array. Intelligent software algorithms calculate the exact distance to the object from the position of the reflectance center on the array. This enables the measuring and switching R10x and R20x sensors to precisely measure the position of an object and clearly distinguish it from the background.



Interference-free distance measurements in the near range



Proven technology in small housing design



Precise object detection

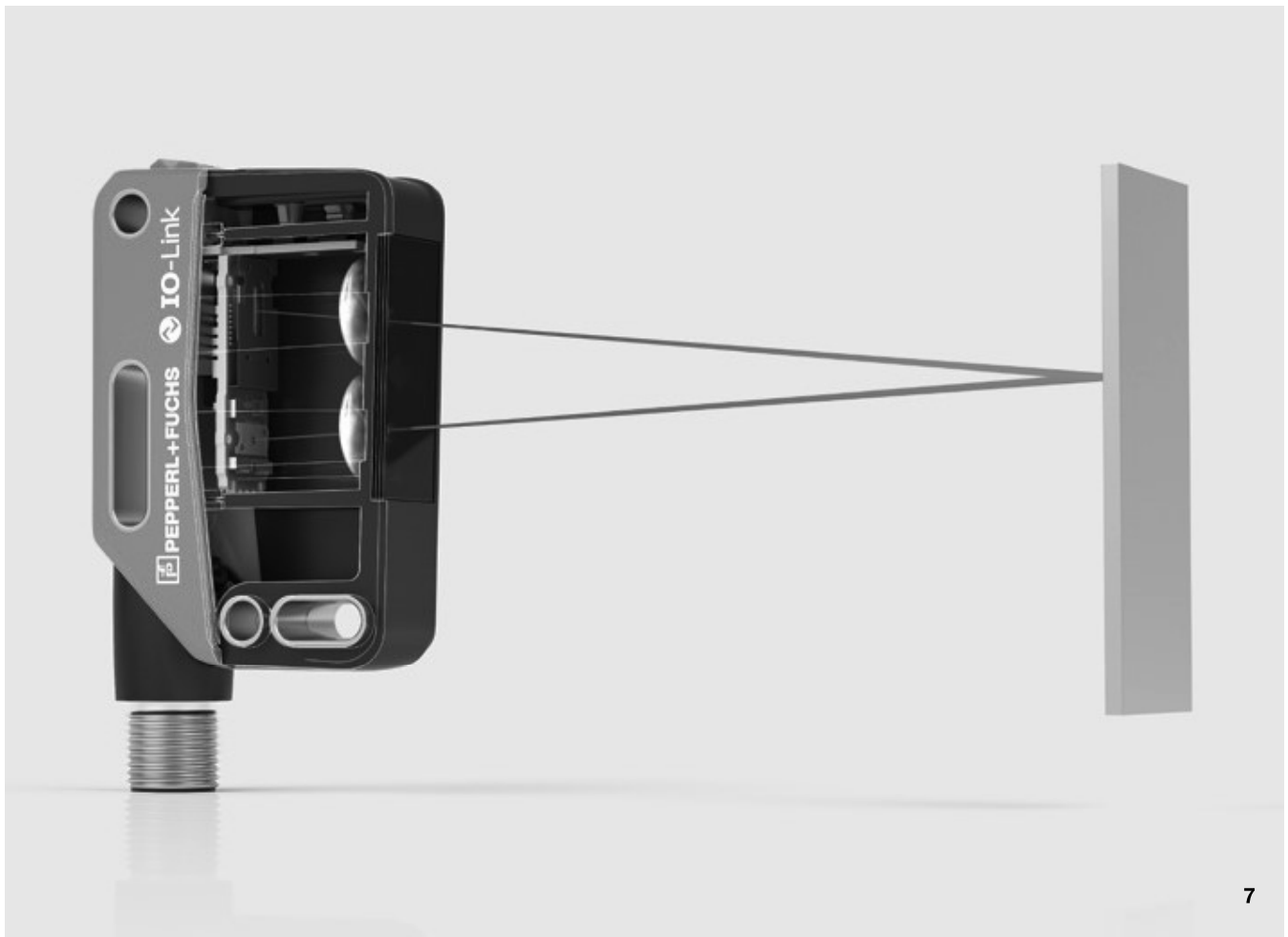

R10x Series at a Glance

All Sensing Modes in a Small Housing



R100, R101 and R103 Series

Maximum performance in space-saving housings—that is what R10x series sensors offer. Three standard housing styles are available with all sensing modes. Depending on the installation and mounting conditions, the perfect sensor can be selected for each application.

PowerBeam LED, DuraBeam laser, and special infrared models are available.

R100/R101/R103 Series		LED IO-Link	DuraBeam Laser IO-Link
Sensing Modes	Type Code	Detection/ Sensing Range	Detection/ Sensing Range
Thru-beam sensor	OBE*-R100*; OBE*-R101*	0 ... 12 m 0 ... 20 m (IR)	0 ... 20 m
	OBE*-R103*	0 ... 10 m	0 ... 20 m
Retroreflective sensor with polarization filter	OBR*-R100*; OBR*-R101*	0.03 ... 7.5 m	0.2 ... 12 m
	OBR*-R103*	0.03 ... 6 m	0.25 ... 12 m
Retroreflective sensor without polarization filter	OBR*-R100*; OBR*-R101*	0.03 ... 7 m (IR)	
Retroreflective sensor for clear object detection	OBG*-R100*; OBG*-R101*	N: 0 ... 5 m Cl-III: 0 ... 3.5 m	
	OBG*-R103*	0 ... 4 m 0 ... 3.5 m	
Diffuse mode sensor	OBD*-R100*; OBD*-R101*	2 ... 1000 mm	
	OBD*-R103*	2 ... 1100 mm (IR) 2 ... 800 mm	
Diffuse mode sensor with background suppression	OBT*-R100*; OBT*-R101*	5 ... 350 mm	7 ... 100 mm
	OBT*-R103*	5 ... 350 mm (IR) 5 ... 300 mm	7 ... 300 mm 7 ... 250 mm
Diffuse mode sensor with background evaluation	OBT*-R100*-1T; OBT*-R101*-1T	5 ... 350 mm	7 ... 100 mm
	OBT*-R103*-1T	5 ... 350 mm (IR) 5 ... 300 mm	7 ... 300 mm 7 ... 250 mm
Measuring sensor with multiple switch points	OQT*-R100*; OQT*-R101*	5 ... 150 mm	8 ... 150 mm
	OQT*-R103*	5 ... 150 mm (IR) 5 ... 120 mm	8 ... 120 mm
Distance sensor	OMT*-R100*; OMT*-R101*	20 ... 50 mm	20 ... 50 mm
		40 ... 100 mm	40 ... 100 mm
	OMT*-R103*	60 ... 200 mm	60 ... 150 mm
		15 ... 45 mm 40 ... 100 mm 60 ... 150 mm	15 ... 45 mm 40 ... 120 mm



IO-Link

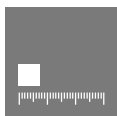

Small-sized



Infrared
R100, R101

R100 Series

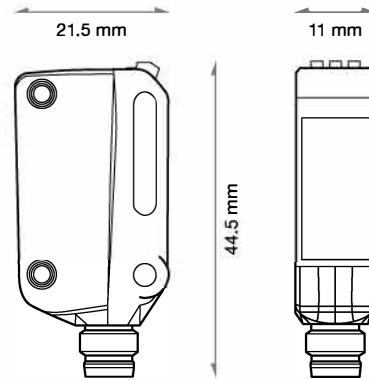

R101 Series

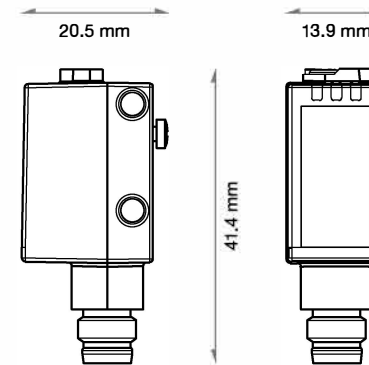

R103 Series

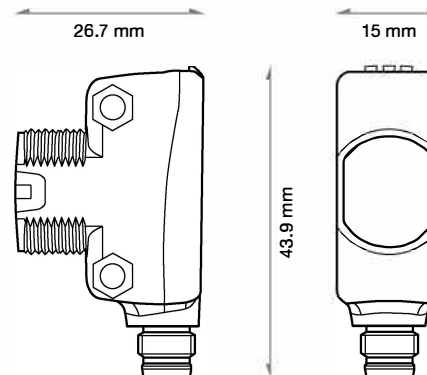

R10x Series Applications

Solutions for Tight Spaces

Industry-standard, easy-to-install housing styles with DuraBeam and Multi Pixel Technology (MPT) make the R10x series perfect for a wide range of applications that require versatility, reliable detection, and precise measurement.

Precise Detection and Measurement of Small Objects (1)

The quality of automated processes in many applications depends on reliable detection and measurement of small objects or object features. Missing parts can interrupt assembly or packaging processes, and position errors prevent further automated processing steps.

Small R10x series distance sensors solve these kinds of challenges with maximum reliability. Their DuraBeam laser technology creates a sharp, circular light spot that reliably detects even the smallest objects. MPT enables micrometer-accurate distance measurement, detecting even miniature product features and the slightest position deviations.

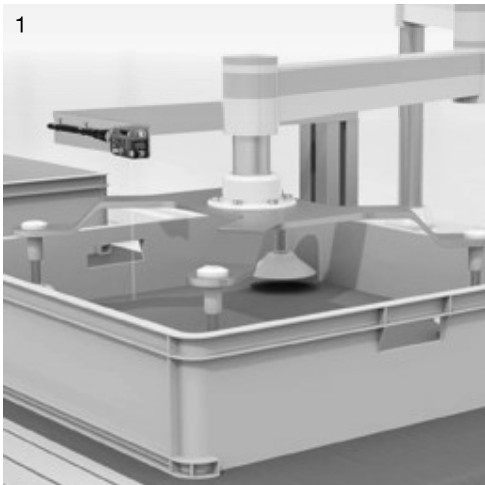

Two Switch Points—One Sensor for Material Handling (2)

Detecting the stack height in a container and simultaneously triggering the next container—R10x switching sensors with measurement core and MPT make it possible to automate two process steps with one device. This increases efficiency in a number of processes while cutting hardware, cabling, and setup costs in half.

These sensors' compact measurement core makes the double detection possible. It allows two separate distance inputs to be evaluated and then output as independent switching points. IO-Link and a wide range of operating modes add flexibility—advantages that mid-sized R20x series sensors also offer.

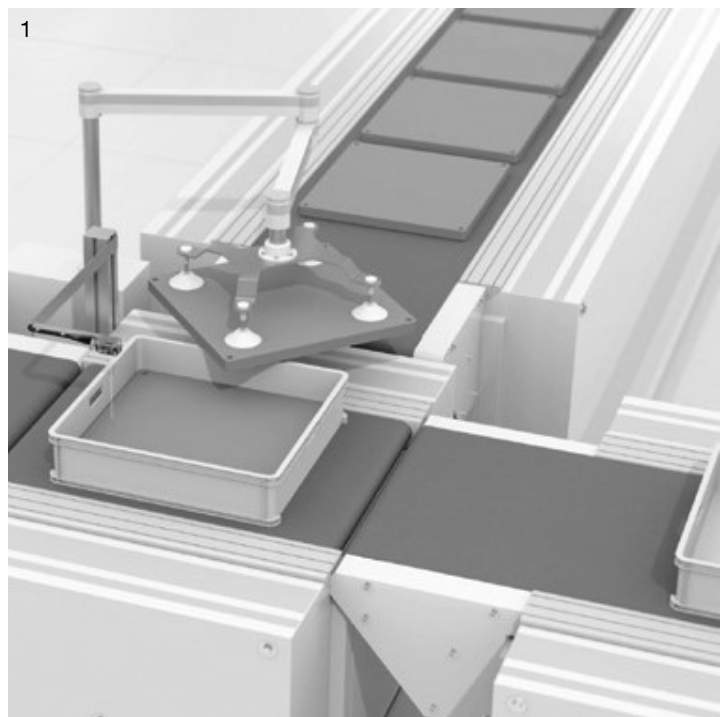

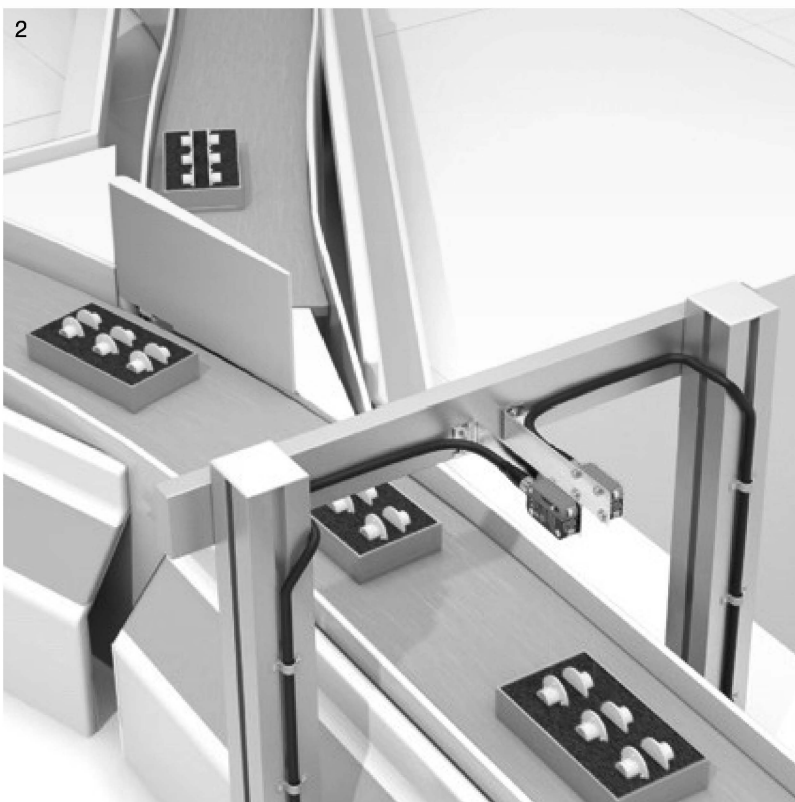
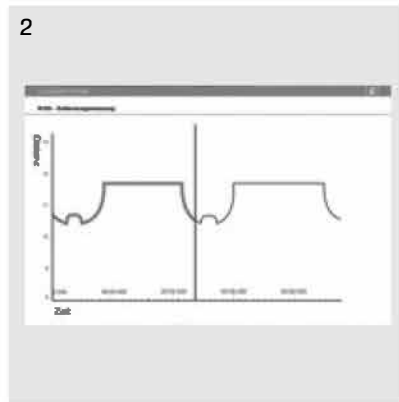
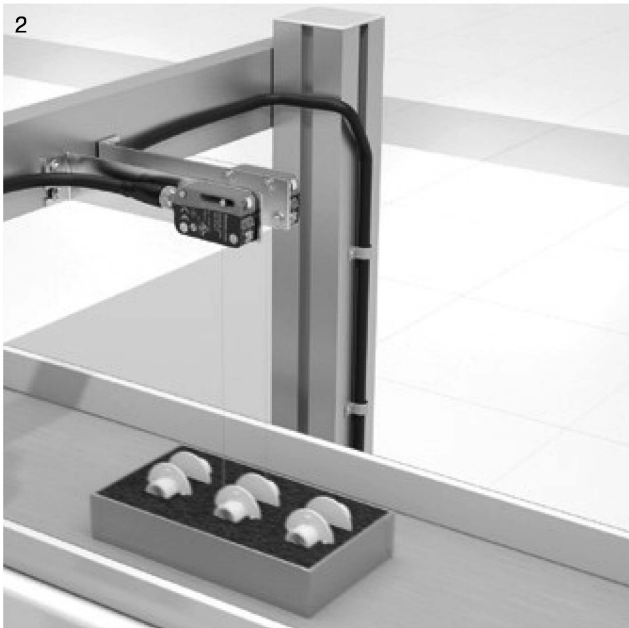

R20x Series at a Glance

All Sensing Modes in a Medium-Sized Housing



R200 and R201 Series

All sensing modes, one user interface, high-performance sensor technology, and IO-Link in every model—medium-sized R200 and R201 series sensors offer the same advantages as the R10x. Extended detection and sensing ranges, and a rotatable connector also allow even more flexibility and extended application possibilities.

R200/R201 Series		LED	DuraBeam Laser
Sensing Modes	Type Code	IO-Link	IO-Link
		Detection/ Sensing Range	Detection/ Sensing Range
Thru-beam sensor	OBE*-R20*	0 ... 25 m	0 ... 40 m
Retroreflective sensor with polarization filter	OBR*-R20*	0,02 ... 15 m	0,5 ... 25 m
Retroreflective sensor for clear object detection	OBG*-R20*	0 ... 8 m	
Diffuse mode sensor	OBD*-R20*	2 ... 1400 mm	
Diffuse mode sensor with background suppression	OBT*-R20*	30 ... 300 mm 10 ... 650 mm	40 ... 600 mm
Diffuse mode sensor with background evaluation	OBT*-R20*-1T	30 ... 300 mm 10 ... 650 mm	40 ... 600 mm
Measuring sensor with multiple switch points	OQT*-R20*	40 ... 400 mm	
Distance sensor	OMT*-R20*	100 ... 300 mm 100 ... 550 mm	



IO-Link

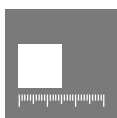

Medium-sized



Swiveling Plug

R200 Series

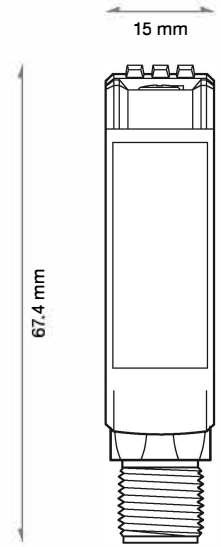
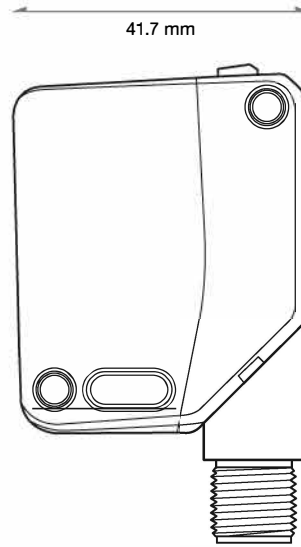

R201 Series

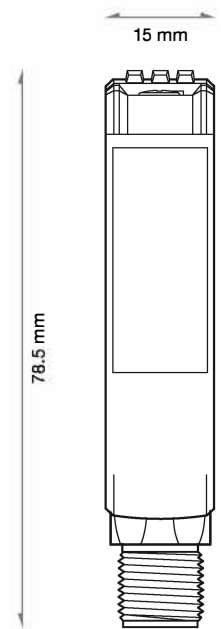
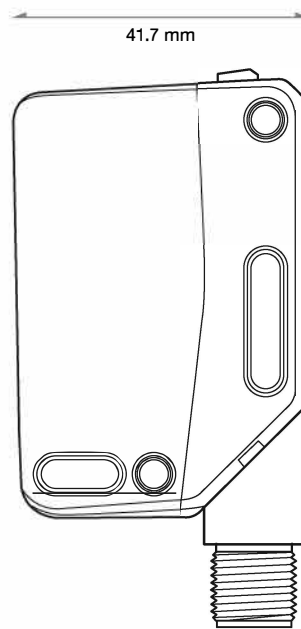

R20x Series Applications

Medium-Sized Sensors—Maximum Performance

R200 and R201 series are the latest additions to Pepperl+Fuchs' forward-thinking family of photoelectric sensors. Identical to the R10x series in terms of technologies and sensing modes, these medium-sized sensors are designed for longer-range applications.

Versatility for Automotive Assembly (1)

In automotive plants, robots assemble side panels on bodies that are transported into a production cell on skids. Only one skid can be in the robot cell at a time and incoming skids must be stopped in front of it. Side panels are supplied on racks and removed by handling robots.

Reliable Skid Control (2)

The skids being guided to the robot cell are controlled by R20x series retroreflective sensors. The sensor is equipped with a polarization filter that ensures reliable detection despite all the reflective surfaces and extraneous light. As soon as a skid passes the first sensor, its speed is reduced. When it reaches the second sensor, the skid is stopped.

Position Verification (3)

To enable the handling robot in the production cell to grip the side panels correctly and remove them from the rack, R20x series distance sensors first measure the distance to the side panel—with extreme precision thanks to high-resolution MPT.

Detection of Microparts (4)

After position verification, R20x diffuse-mode sensors with background suppression verify the presence and proper attachment of screws to the B and C columns. The small, sharp light spot made possible by DuraBeam technology ensures reliable verification of even the smallest components on the side panels.

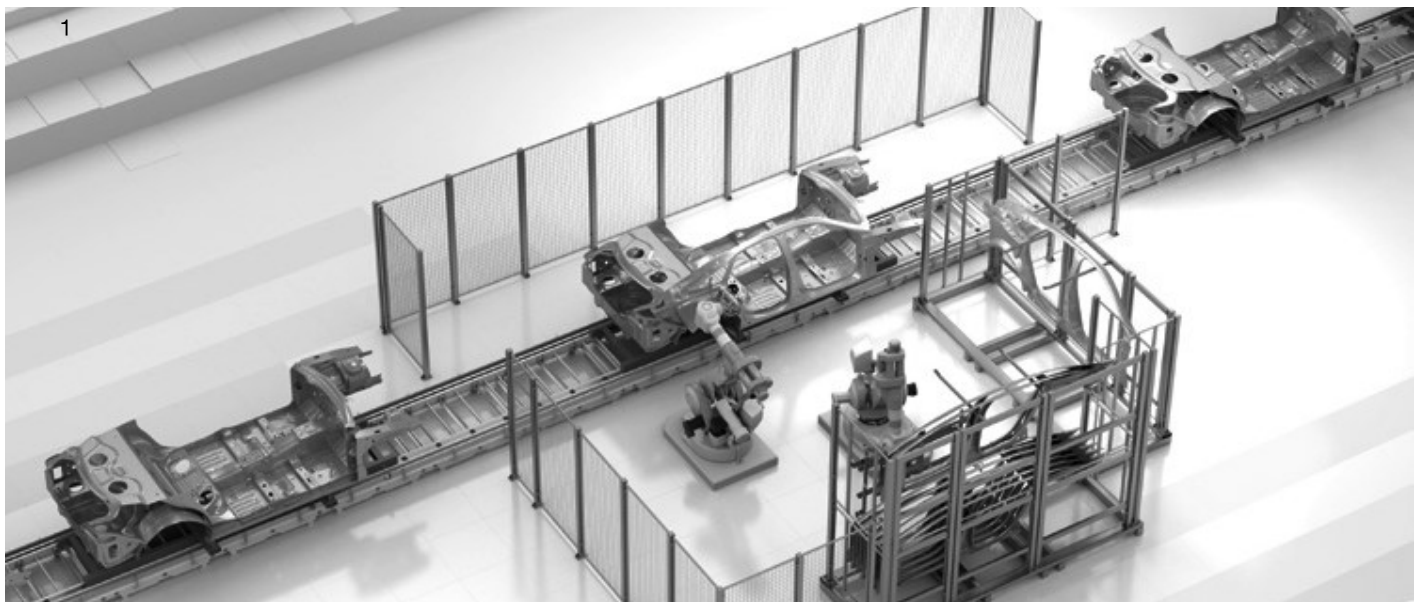

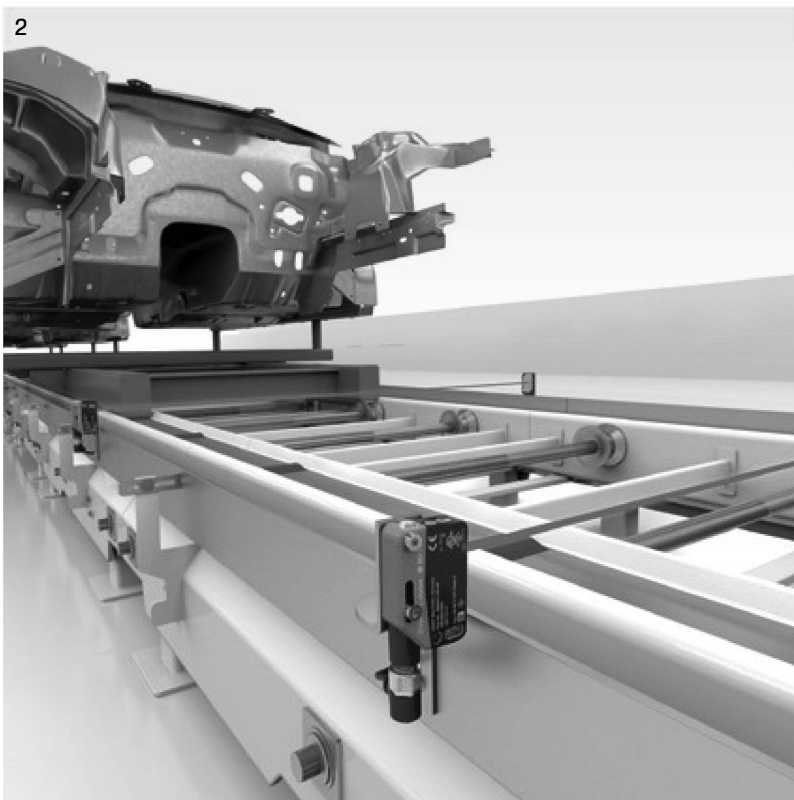
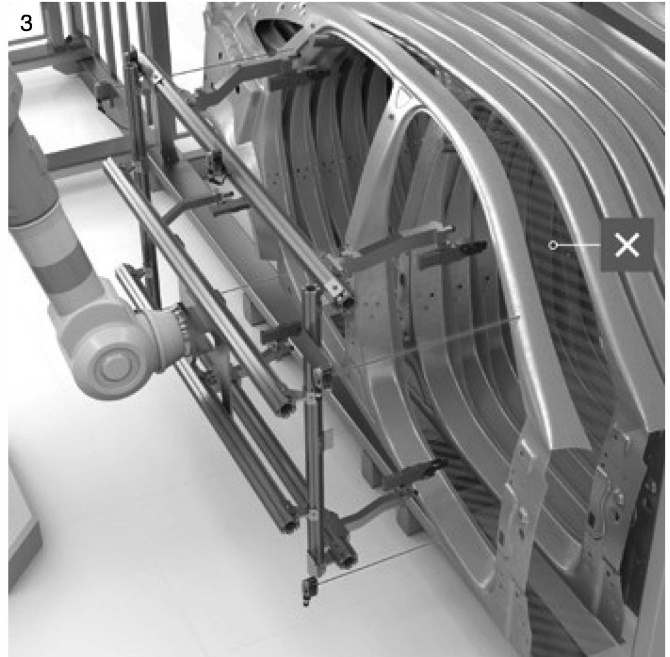
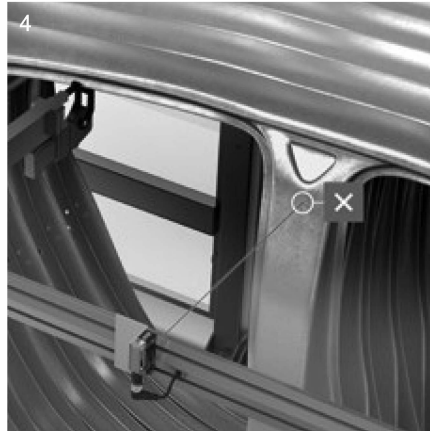
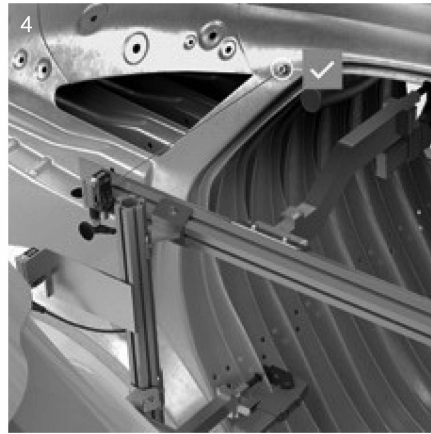

R20x Series Applications

Reliable Detection at Every Stage of Bottling

Tens of thousands of bottles are filled per hour in high-capacity bottling plants. Since any incorrect or missing switching signal can seriously disrupt the filling and packaging process, reliable detection is a must.

Detecting Transparent Objects (1)

Reflections and other effects caused by shiny, curved surfaces are significant challenges for photoelectric sensors used to detect PET and clear glass bottles. R20x series retroreflective sensors detect and count clear glass bottles with extreme reliability to prevent false trips or incorrect counting in filling lines, and gaps in the bottle flow are detected reliably.

A Pepperl+Fuchs sensor system for detecting transparent objects is used when packs of finished bottles are wrapped. It consists of a retroreflective sensor and a reflector with circular polarization filter and uses depolarization to increase detection reliability. This sensor system provides reliable presence control of the transparent stretch film.

Monitoring Bottle Cap Feed (2)

To seal bottles after filling, R20x series distance-based diffuse-mode sensors monitor the automated bottle cap feeding process. Multi Pixel Technology (MPT) makes it possible to monitor several points simultaneously with one sensor: correct cap feed, cap in the incorrect rotary position, and cap with damage. This ensures the accuracy and reliability of the capping process.

Flexibility for All Installation Requirements

While medium-sized R20x series sensors are perfect for bottling plants or automotive assembly, among other applications, R10x series miniature sensors offer the same functionality and solutions for space-restricted installations.



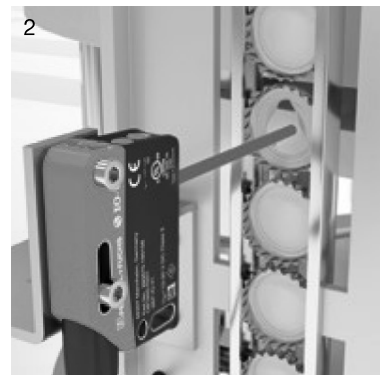
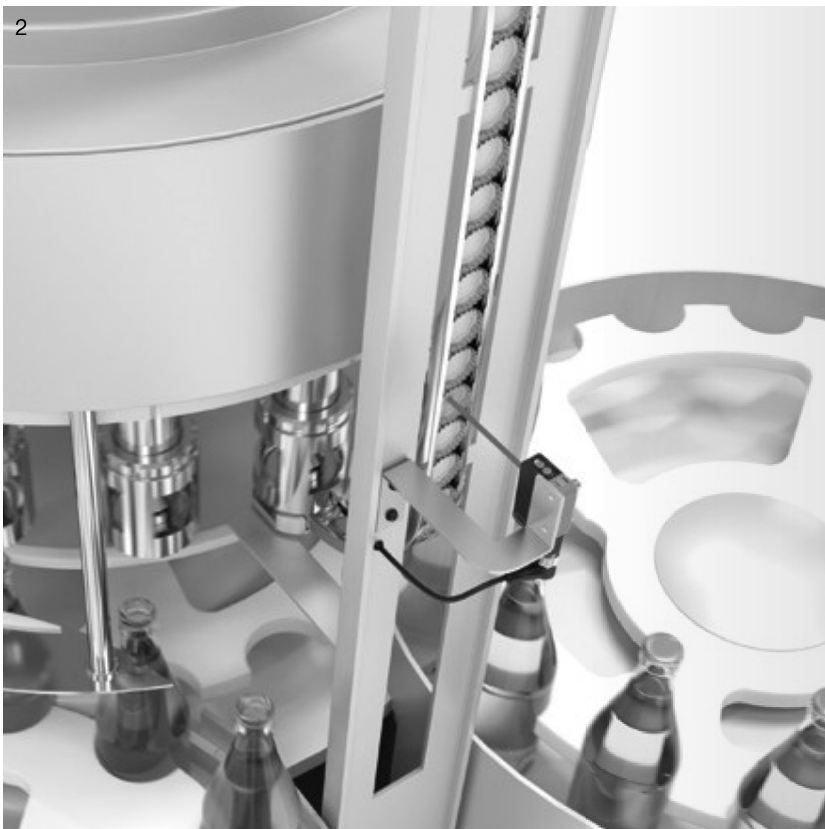
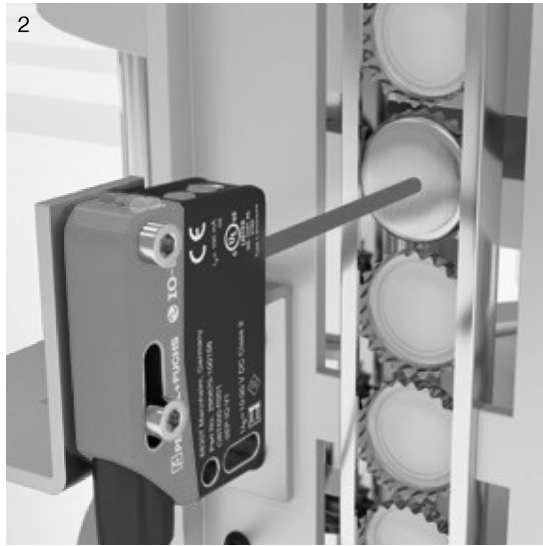
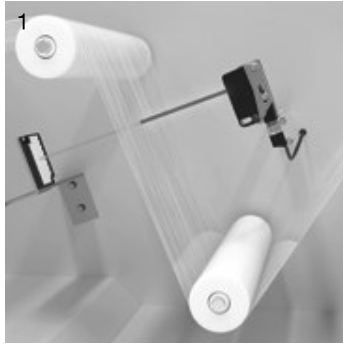



HAGER-PULSAR
PN 26705-0000
OBT300-R100
2EP-10-021
 $U_N = 10-30 \text{ V DC}$
Class 2
Type 1 enclosure
CE

HAGER-PULSAR
PN 26705-0000
OBT300-R100
2EP-10-021
CE

HAGER-PULSAR
PN 26705-0000
OBT300-R100
2EP-10-021
CE

HAGER-PULSAR
PN 26705-0000
OBT300-R100
2EP-10-021
CE



Your automation, our passion.

Explosion Protection

- Intrinsic Safety Barriers
- Signal Conditioners
- FieldConnex® Fieldbus
- Remote I/O Systems
- Electrical Ex Equipment
- Purge and Pressurization
- Industrial HMI
- Mobile Computing and Communications
- HART Interface Solutions
- Surge Protection
- Wireless Solutions
- Level Measurement

Industrial Sensors

- Proximity Sensors
- Photoelectric Sensors
- Industrial Vision
- Ultrasonic Sensors
- Rotary Encoders
- Positioning Systems
- Inclination and Acceleration Sensors
- Fieldbus Modules
- AS-Interface
- Identification Systems
- Displays and Signal Processing
- Connectivity



CBC

CARLTON-BATES COMPANY®
A SUBSIDIARY OF WESCO DISTRIBUTION, INC.

PF PEPPERL+FUCHS

Subject to modifications • © Pepperl+Fuchs
Printed in Germany • Part. No. 318216 04/18 00