

HCLB Series Resistor Load Banks

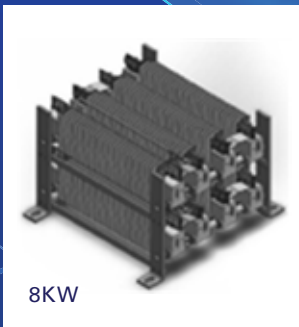

8KW

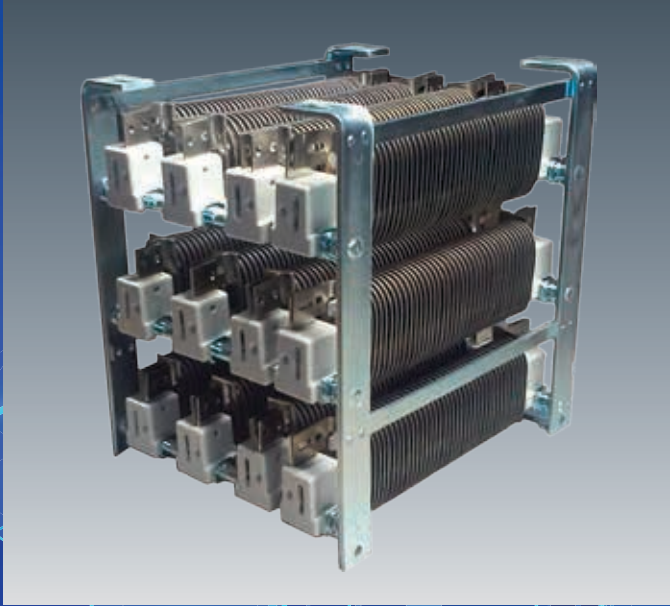
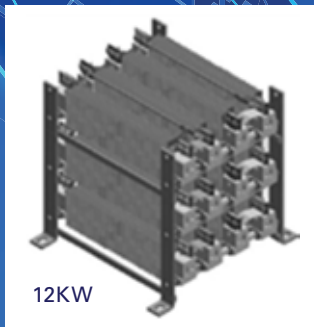

12KW



15KW

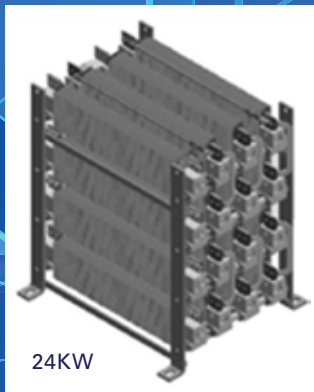

24KW

NOTE: Load banks require significant investment in resistance wire due to high minimum order quantities imposed by our vendors. Before ordering, always check with the factory on wire availability.

High Current Oval Edgewound

The choice when conditions demand top-notch performance, these resistor load banks are commonly used for dynamic braking on Transit applications or where high current handling and wattage are required. Ohmite's unique Oval Edgewound design allows for more wattage in smaller a package. Choose from four bank wattages with up to thirty-one current ratings per bank.

Built to perform in rugged environments, Ohmite load banks feature corrosion resistant stainless steel insulator supports, solid nickel terminals, and special electroless nickel-plated solid copper terminal supports. The resistance element is made of a stainless steel resistance alloy. Terminals are welded or silver brazed to the oval, spiral edgewound resistance element. Toothed ceramic insulators isolate the resistance element from the center support. Ceramic end bushings insulate the center support from the mountings.

CHARACTERISTICS

Current Rating

Continuous duty as listed below.

Wattage Rating

Continuous duty based on a 375°C temperature rise.

Working Voltage

Limited to 1000 volts if mounting is grounded. Special higher voltage mounting is available.

Resistance Tolerance

±10%.

Terminals / Jumpers

Standard terminals have 5/16 stainless hardware for ring lug connections. Brass tags can be placed at connection points for identification. If necessary, all connections can be made on one side of grid. Fixed tap terminals are also available. Jumpers between resistors are nickel-plated solid copper.

Mounting

Resistor Banks can be produced in grid arrays of 2 x 4 to 4 x 4. All resistors in one grid are the same length. Frames are constructed of heavy-gauge zinc-plated steel. Either "bolt up" or "bolt down" type frames are available. Frames may be grounded if voltage potential is below 1000 volts.



CBC

CARLTON-BATES COMPANY
A SUBSIDIARY OF WESCO DISTRIBUTION, INC.

OHMITE®

DIMENSIONS

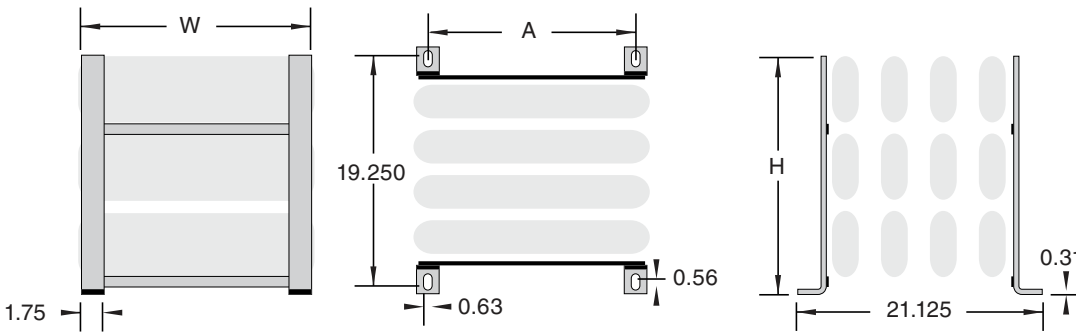

Type	A	H	W
8KW	16.50	12.875	18.25
2KW	16.50	18.875	18.25
15KW	16.50	24.94	18.25
24KW	19.88	24.94	21.63

Dimensions for reference only;
Consult factory for details.

ORDERING INFORMATION

HCLB - 12 - R165 E

Series
High Current
Load Bank

Wattage
08 = 8KW
12 = 12KW
15 = 15KW
24 = 24KW

Resistance

RoHS Compliant

8K Watt

Resistance	Current	Wattage
0.099	285	8,041
0.122	257	8,049
0.144	236	8,020
0.165	221	8,044
0.248	180	8,019
0.284	168	8,027
0.286	167	7,982
0.333	155	8,000
0.360	149	7,992
0.383	145	8,061
0.412	140	8,070
0.418	139	8,068
0.482	129	8,013
0.562	120	8,087
0.576	118	8,020
0.659	110	7,971
0.680	109	8,084
0.711	106	7,989
0.770	102	8,015
0.833	98	7,995
0.878	96	8,095
1.145	84	8,078
1.215	81	7,972
1.373	76	7,928
1.534	72	7,950
1.636	70	8,017
1.701	69	8,098
1.920	65	8,112
1.944	64	7,963
2.246	60	8,087
2.448	57	7,954
3.168	50	7,920
4.091	44	7,919
6.120	36	7,932
11.025	27	8,037

12K Watt

Resistance	Current	Wattage
0.165	270	12,029
0.203	244	12,092
0.240	224	12,042
0.275	210	12,105
0.321	194	12,081
0.366	181	11,991
0.474	159	11,983
0.495	156	12,046
0.555	147	11,993
0.609	140	11,942
0.660	135	12,029
0.720	129	11,982
0.810	122	12,056
0.915	115	12,101
0.960	112	12,042
1.134	103	12,031
1.320	96	12,165
1.464	90	11,858
1.665	85	12,030
1.896	80	12,134
2.220	73	11,830
2.430	70	11,907
2.745	66	11,957
3.240	61	12,056
3.660	57	11,891
3.744	57	12,164
3.960	55	11,979
4.080	54	11,897
5.280	48	12,165
7.350	40	11,760
8.181	38	11,813
12.240	31	11,763
16.320	27	11,897
22.050	23.5	12,177

15K Watt

Resistance	Current	Wattage
0.220	261	14,987
0.271	236	15,082
0.320	217	15,068
0.366	203	15,082
0.428	187	14,967
0.488	175	14,945
0.550	165	14,974
0.632	154	14,989
0.740	142	14,921
0.800	137	15,015
0.880	130	14,872
0.928	127	14,968
1.070	118	14,899
1.220	111	15,032
1.280	108	14,930
1.512	99	14,819
1.760	92	14,897
1.850	90	14,985
2.130	84	15,029
2.320	80	14,848
2.544	77	15,083
2.700	74	14,785
2.960	71	14,921
3.050	70	14,945
3.120	69	14,854
3.780	63	15,003
4.320	59	15,038
4.400	58	14,802
4.880	55	14,762
5.440	52	14,710
7.040	46	14,897
9.090	41	15,280
9.800	39	14,906
13.600	33	14,810
21.760	26	14,710
24.500	24.5	14,706

24K Watt

Resistance	Current	Wattage
0.328	271	24,089
0.82	171	23,978
0.976	157	24,057
1.112	147	24,029
1.312	135	23,911
1.344	133	23,774
1.416	130	23,930
1.904	112	23,884
2.272	102	23,638
2.292	102	23,846
2.44	99	23,914
2.78	93	24,044
3.36	84	23,708
3.54	82	23,803
3.904	78	23,752
4.448	73	23,703
4.76	71	23,995
5.376	67	24,133
5.664	65	23,930
5.68	65	23,998
5.73	64.5	23,838
7	58	23,548
7.616	56	23,884
9.088	51	23,638
9.168	51	23,846
10.32	48	23,777
17.5	37	23,958
25.8	30.5	24,000
28	29	23,548
41.28	24	23,777